

Ultraviolet Germicidal Lamps Installation and Service Manual

I. SAFETY INSTRUCTIONS

Please read the safety and installation instructions carefully to help ensure a correct and SAFE installation of the Aprilaire Ultraviolet Germicidal Lamp.

WARNING

Ultraviolet light is harmful to eyes and skin. Never look at light produced by this lamp. Unplug lamp before servicing.

Electrical shock from 120 VAC may cause serious injury. Disconnect power before starting installation and keep disconnected until complete. The lamp has a grounding-type (3 prong) plug that will fit only into a grounding-type power outlet. Do not alter plug in any way.

Sharp edges may cause personal injury. Use care when cutting and handling sheet metal.

Lamp may cause personal injury in the form of burns or cuts. Wear protective gloves and safety glasses when handling lamp. To prevent burns, unplug lamp and allow to cool for several minutes before servicing. If lamp is broken, refer to lamp disposal section of this manual.

CAUTION

1. UV light can cause color changes or structural degradation of plastics, rubber, paper, and other non-metallic materials used in the HVAC system.

- Install lamp in location that prevents exposure of plastics, rubber, paper, and other non-metallic materials to UV light, or shield such materials with aluminum tape, sheet metal, or metal conduit.
- Shield electrical wires that receive direct or reflected UV radiation with aluminum tape, sheet metal, or conduit.
- Do not install in flex duct. If the UV resistance of the flex duct is not known, install lamp at least 6 feet away from flex duct. If the flex duct is UV resistant, lamp may be installed as close as 3 feet.
- Install lamp at least 8 inches away from equipment or components made with UV resistant plastic. If equipment or components are not made with UV resistant plastic – or if the UV resistance of the material is unknown – shield with aluminum tape or sheet metal.

2. Water may damage lamp.

- Do not install lamp inside or under an “A” coil.
- Install lamp at least 3 inches away from an “A” coil.
- Install lamp at least 8 inches away from a horizontal coil.
- Do not install lamp below a humidifier or any source of water.

II. APPLICATION

Aprilaire Ultraviolet Germicidal Lamps are designed for the treatment of evaporator coils used in air conditioners or heat pumps in a HVAC system. The lamps will kill microorganisms growing on evaporator coils and drain pans and prevent further growth. The units are designed for continuous lamp operation. Model 1910 is a Single Base Unit and Model 1930 is a Dual Base Unit. The units are 120 VAC / 60 Hz. See Figures 1 - 3 for unit schematics.

III. INSTALLATION

- The installation should be done by a qualified HVAC contractor.
 - Read all safety instructions at the beginning of this manual. Failure to do so could lead to personal injury and/or equipment damage.
 - In cases where fungi and/or bacteria are already present on the evaporator coil, it is recommended that a qualified HVAC service technician clean the coil before the installation of the UV Lamp. Because the Aprilaire Ultraviolet Germicidal Lamp quickly kills fungi and bacteria, there could be an initial period of temporarily increased levels of airborne decay products if the coil is not cleaned before installation.
 - Do not wire this unit into a switched outlet or operate the unit intermittently; this will significantly reduce the life and effectiveness of the lamp.
 - Except where noted, these instructions apply to Models 1910 and 1930. For the Model 1930, install the primary or LEFT UNIT FIRST, then the secondary or RIGHT UNIT. The two units are connected by a power cord 29" long. See Figure 2.
 - The tools and equipment required to complete this installation include: the template; a tape measure; 5/16" & 11/32" nut driver (or a socket set); 1/8", 1/4", & 3/8" drill bits; a drill; and a pair of left-handed and right-handed sheet metal cutters. A digital multi-meter might also be needed.
-
1. Determine a mounting location for the lamp. Use the criteria below to select a proper location:
 - a. The lamps are intended for evaporator coil treatment. See Figures 4 - 7 for guidelines on mounting locations.
 - b. Install lamp in location that prevents exposure of plastics, rubber, paper, and other non-metallic materials to UV light, or shield such materials with aluminum tape, sheet metal, or metal conduit. **See CAUTION statements at beginning of manual for more details.**
 - c. To protect lamp, do not install lamp below any source of water.
 - d. Install units so that LAMP ASSEMBLY is at least 3 inches away from evaporator coil surface.
 - e. Install lamp in a location that can be easily accessed. Allow 20 inch clearance to slide lamp in and out of duct. See lamp dimensions in Figures 1 & 2. For Model 1930, when considering mounting location, keep in mind the 29" cord length that connects the LEFT and RIGHT units.
 - f. Be certain the area in the duct where you intend to drill and cut is free of any obstructions or components that would be damaged by the installation or interfere with the installation.
 - g. While keeping these guidelines in mind, the more direct exposure the coil and drain pan receive, the greater the benefit the lamps will have.
 2. Using the template that is supplied with this manual, mark the location of a rectangular opening for the LAMP ASSEMBLY and 5 holes, 4 of which will be required to mount the UNIT BASE and 1 for the HOLE FOR SIGHT GLASS. **When considering placement of lamp, note that the LAMP ASSEMBLY is off-center, relative to the base.**
 3. Carefully inspect the HVAC system and make sure that no damage will occur as a result of drilling the 5 holes.
 4. Drill four 1/8" diameter holes at the marked location of the 4 mounting holes.
 5. Drill a 1/4" hole at the marked location for the hole that allows UV light to be seen through the SIGHT GLASS.
 6. Drill a 3/8" diameter hole into the duct at one corner of the rectangular slot.
 7. Starting at the 3/8" hole, cut a 2 1/4" x 4 1/8" rectangular opening.
 8. Check that the UNIT BASE, with the LAMP ASSEMBLY attached, can be placed through the rectangular opening in the duct and that the UNIT BASE fully contacts the duct.
 9. Apply foam tape (included) to the side of the UNIT BASE that is in contact with the duct. The purpose of the foam tape is to prevent UV light from being seen through cracks between the UNIT BASE and duct.
 10. Use alcohol to remove any dirt and/or fingerprints from the LAMP.
 11. Attach UNIT BASE, with LAMP ASSEMBLY in place, using 4 self-tapping sheet metal screws and the pre-drilled holes.
 12. Attach the UNIT HOUSING and secure it with two NUTS that are placed over the studs mounted on the base.
 13. Repeat steps 2-11 for the RIGHT UNIT of Model 1930.
 14. Place three WARNING labels (included) on the duct: one on the duct near the UV lamp and the other two on opposite sides of the plenum, near the furnace/air handler.
 15. Plug the POWER CORD into a 120 VAC power outlet that is always energized.
 16. Turn the lamp's ON/OFF SWITCH to the 'On' position. (1930 has ON/OFF SWITCH on each unit.)

IV. CHECK LAMP OPERATION

Check operation of the lamp using the following procedure. These instructions apply to Model 1910 and both units that make up Model 1930.

1. Plug the lamp's POWER CORD into a standard 120 VAC outlet that is always energized.
2. Turn the lamp's ON/OFF SWITCH to the 'On' position. (1930 has ON/OFF SWITCH on each unit.)
3. Look at the SIGHT GLASS located in the bottom center of the UNIT HOUSING. (See Figure 1). If the lamp is operating correctly, the SIGHT GLASS will be illuminated by blue light. If not, see the 'Troubleshooting' section for additional steps.
4. Look for any stray UV light and apply the proper caulk or aluminum tape to eliminate.

V. ANNUAL LAMP REPLACEMENT

The Aprilaire Ultraviolet Germicidal Lamp is designed for the lamp to be on at all times. After 9,000 hours of operation – 1 year of constant use – the effectiveness of the lamp inside the unit diminishes and needs to be replaced. Rarely will a lamp burn out in one year of continuous use; replacement is necessary because the lamp's intensity decreases. Installation of the replacement lamp (Aprilaire Service Part #90) is best handled by a qualified HVAC Service Contractor.

Lamp Replacement Instructions (see Figures 1 - 3):

- a. Switch ON/OFF SWITCH to 'Off' and unplug POWER CORD. Wait several minutes for lamp to cool before proceeding.
- b. Loosen NUTS that secure UNIT HOUSING to BASE then remove UNIT HOUSING.
- c. Loosen LAMP DOOR SCREW that secures LAMP DOOR to BASE.
- d. Carefully pull LAMP ASSEMBLY out from duct. This requires that you slightly lift up and tilt forward the LAMP ASSEMBLY while pulling out from the BASE.
- e. Remove LAMP by pulling it out from LAMP SOCKET and out from LAMP HOLDER.
- f. Install new, replacement LAMP (Aprilaire Service Part #90) into LAMP SOCKET and LAMP HOLDER. Be sure LAMP is fully inserted into LAMP SOCKET.
- g. Use alcohol to remove any dirt and/or fingerprints from the new LAMP.
- h. Return LAMP ASSEMBLY to BASE and fasten LAMP DOOR SCREW.
- i. Put UNIT HOUSING back in place and fasten NUTS. Be sure UNIT HOUSING rests completely on the BASE and that all wiring is fully inside.
- j. Plug in POWER CORD and turn ON/OFF SWITCH to 'On.' If the lamp is operating correctly, the SIGHT GLASS will be illuminated by blue light.
- k. In the Owner's Manual, record the date the lamp was replaced so that the date for next replacement is clear.

Under normal conditions, the Aprilaire Ultraviolet Germicidal Lamp should not require any maintenance other than annual lamp replacement.

VI. LAMP DISPOSAL

As with a fluorescent light bulb, your UV lamp contains mercury and must be disposed of properly. **Do not throw old lamps into the trash.** Many communities have agencies that take in mercury along with other materials – such as old paints, solvents, etc. – that require special disposal. Please contact your municipal or county waste collection agency for proper disposal procedures.

If a lamp is broken, **do not use a vacuum cleaner to pick up the waste.** Instead, sweep up the waste into a plastic bag and seal. Contact your municipal or county waste collection agency for proper disposal procedures.

VII. TROUBLESHOOTING

If the SIGHT GLASS does not illuminate, check the following:

Power Cord – Verify that the lamp’s POWER CORD is plugged into a standard 120 VAC outlet that is always energized.

On/Off Switch – Verify that lamp’s ON/OFF SWITCH is in the ‘On,’ position. The switch is illuminated red when powered and in the ‘On’ position. (1930 has ON/OFF SWITCH on each unit.)

Fuse – If the lamp is still not illuminated, place ON/OFF SWITCH to ‘Off’ position, unplug the lamp’s POWER CORD, and check the FUSE. Look to see if FUSE is darkened or visibly blown; or check fuse continuity with multi-meter.

Lamp – Verify that LAMP is not broken and is properly seated into LAMP SOCKET. To check this, follow steps in the ‘Annual Lamp Replacement’ section with one exception: you should not remove and replace lamp (Steps ‘e’ and ‘f’). Instead, simply verify that lamp tube is not broken and that it is firmly pushed into its’ LAMP SOCKET. If necessary, use alcohol to remove any dirt and/or fingerprints from the lamp. If the lamp is broken read the ‘Lamp Disposal’ section of this manual for proper disposal.

Hole for Sight Glass – When the LAMP ASSEMBLY is back in place and with the lamp still unplugged, check to see if there is a hole in the duct behind the sight glass. See Figure 3 for location of HOLE FOR SIGHT GLASS. If there is no hole, carefully drill one using a 1/4” bit.

Ballast – If the lamp is still not illuminated, check the BALLAST. See Figures 8 & 9 for wiring diagrams of the two units.

- a. First check the input power. To do so, unplug POWER CORD and check line voltage at outlet. The voltage should be close to 120 VAC, if it is not contact an electrician.
- b. If the input voltage is OK, check the resistance of the BALLAST. Do this with POWER CORD unplugged. Measure the resistance from the **black** lead on the input side of the BALLAST to the **blue** lead on the output side of the BALLAST. To contact the **blue** lead it may be necessary to remove the lamp and put the multi-meter probe into the corresponding lamp socket opening. The resistance should be in the range of 7 to 12 ohms. If the resistance is less than 7 ohms, replace the BALLAST.

If the resistance of the BALLAST is OK and everything else checks out, but the light still does not illuminate, the starter in the BALLAST is likely shorted out and the BALLAST must be replaced.

List of Replacement Parts (See Figures 1 - 3). The replacement parts are the same for Model 1910 and Model 1930.

Replacement Lamp	#90	Fuse Cap & Holder	#4413
Ballast	#4411	Lamp Socket	#4414
Fuse	#4412	Lighted On/Off Switch	#4415

FIGURES 1 - 3

FIGURE 1 – Model 1910

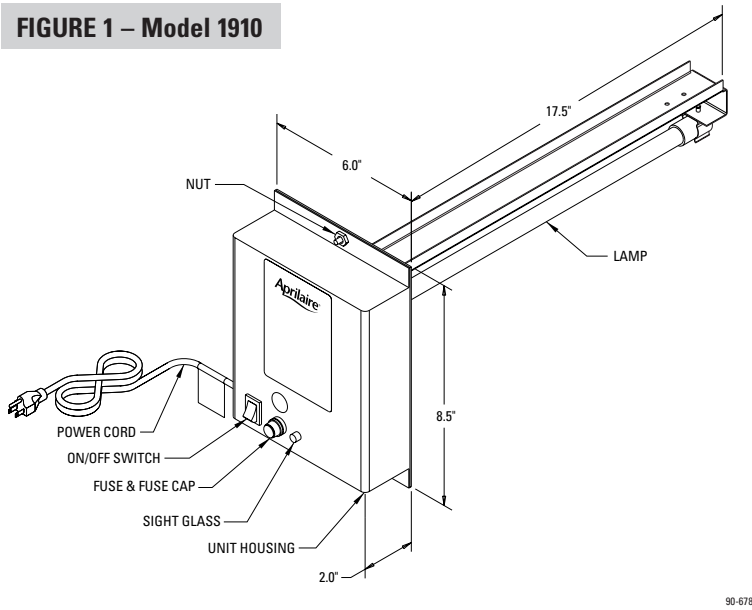

90-678

FIGURE 3

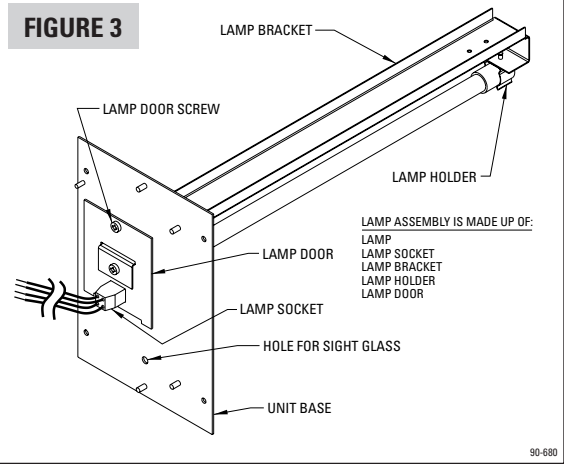

90-680

FIGURE 2 – Model 1930

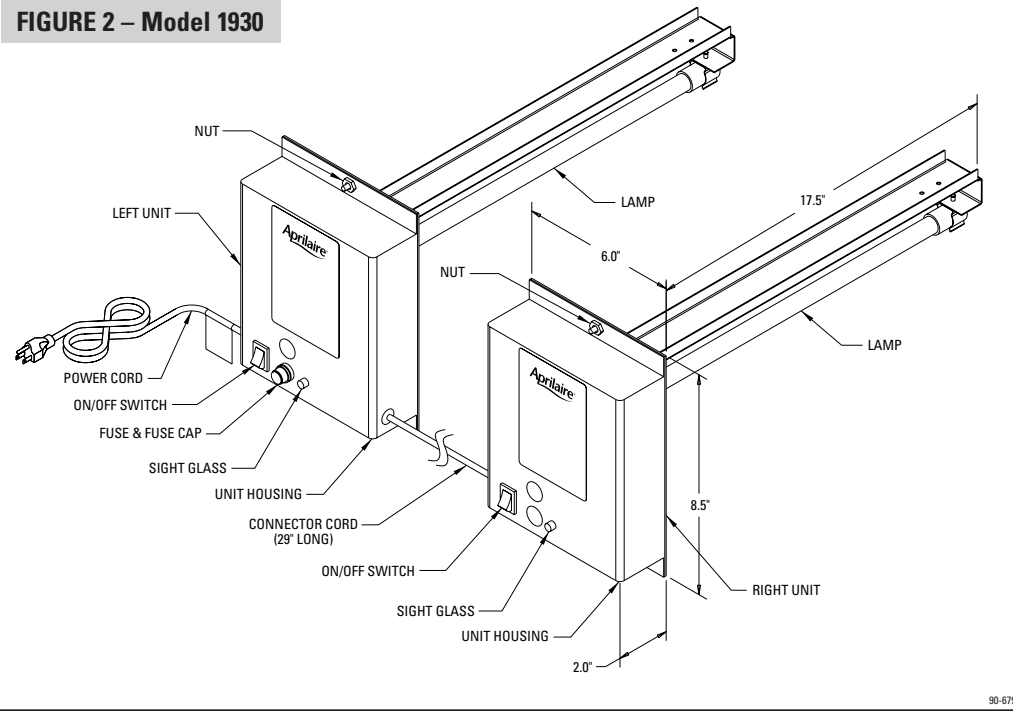

90-679

FIGURES 4 - 9

FIGURE 4 – Model 1910 on Horizontal Coil

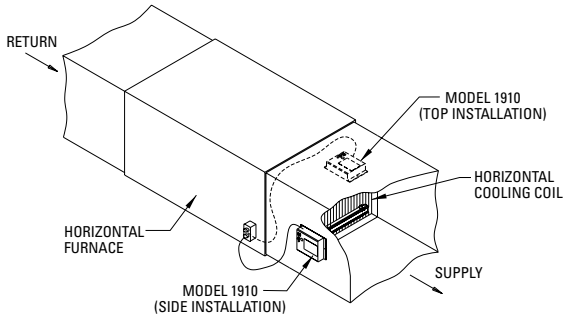

90-681

FIGURE 5 – Model 1930 on Horizontal coil

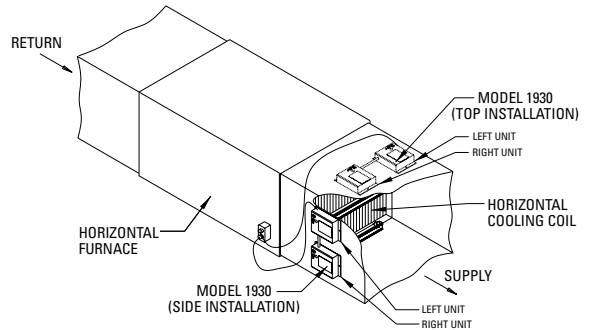

90-682

FIGURE 6 – Model 1910 on "A" Coil

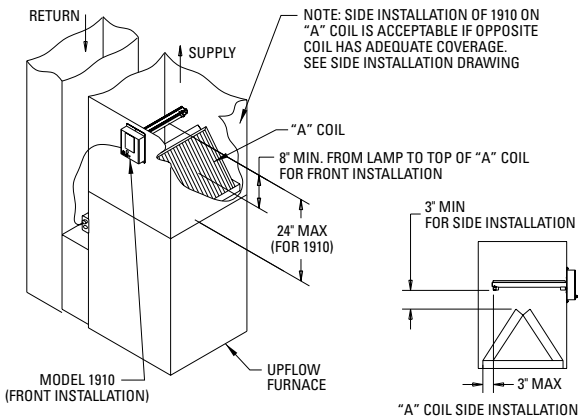

90-683

FIGURE 7 – Model 1930 on "A" Coil

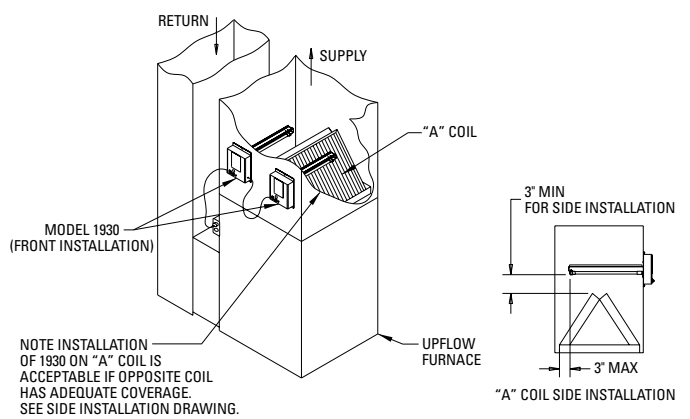

90-684

FIGURE 8 – Model 1910

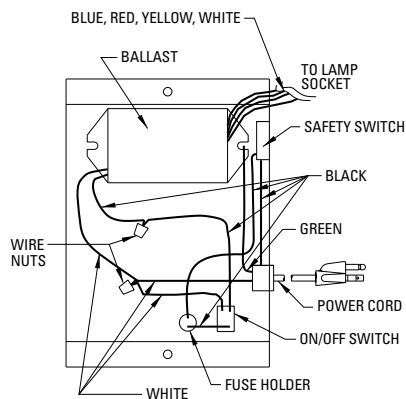

90-686

FIGURE 9

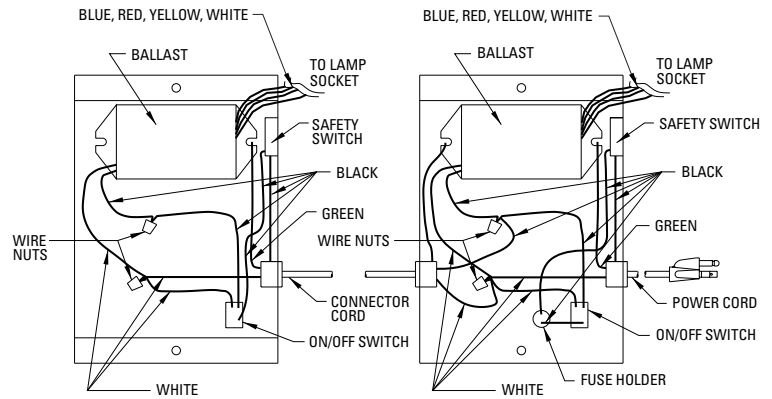

90-687

INSTALLATION TEMPLATE

