

# INSTALLATION INSTRUCTIONS

## G1D91BU, G1D93BC, G1D93BU, CG90CB, & CG90UB High Efficiency 90+ Condensing Gas Furnace

### **WARNING**

Improper installation, adjustment, alteration, service, or maintenance can cause injury or property damage. Refer to this manual. For assistance or additional information, consult a qualified installer, service agency, or the gas supplier.

### **WARNING**

Do not store combustible materials, including gasoline and other flammable vapors and liquids, near the furnace, vent pipe, or warm air ducts. The homeowner should be cautioned that the furnace area must not be used as a broom closet or for any other storage purposes. Such uses may result in actions that could cause property damage, personal injury, or death.

### **WARNING**

This furnace is not approved for installation in a mobile home. Do not install this furnace in a mobile home. Installation in a mobile home could result in actions that could cause property damage, personal injury, or death.

### TABLE OF CONTENTS

SAFETY .....	2
INSTALLATION.....	3
START-UP .....	19
OPERATION .....	20
MAINTENANCE .....	23
REPAIR PARTS .....	24
CONTROL SYSTEM DIAGNOSTICS ..	25
WIRING DIAGRAMS .....	26

Manufactured By  
A.A.C.

*A Lennox International Company*  
421 Monroe Street  
Bellevue, OH 44811



### **IMPORTANT**

The installation of the furnace, wiring, warm air ducts, venting, etc. must conform to the requirements of the National Fire Protection Association; the National Fuel Gas Code, ANSI Z223.1/NFPA No. 54 (latest edition) and the National Electrical Code, ANSI/NFPA No. 70 (latest edition) in the United States; CSA B149.1 (latest edition) Natural Gas and Propane Installation Codes and the Canadian Electrical Code Part 1, CSA 22.1 (latest edition) in Canada; and any state or provincial laws, local ordinances (including plumbing or wastewater codes), or local gas utility requirements. Local authorities having jurisdiction should be consulted before installation is made. Such applicable regulations or requirements take precedence over the general instructions in this manual.

## SAFETY

The following is a list of safety rules and precautions that must be followed when installing this furnace.

1. Use only with the type of gas approved for this furnace. Refer to the furnace rating plate.
2. Install this furnace only in a location and position as specified in the **Location** section on page 3 of these instructions.
3. Provide adequate combustion and ventilation air to the furnace space as specified in the **Combustion and Ventilation Air** section on page 4 of these instructions.
4. Adequate clearance must be provided around the vent-air intake terminals as specified in the **Venting** section beginning on page 5 of these instructions.
5. Combustion products must be discharged outdoors. Connect this furnace to an approved vent system only, as specified in the **Venting** section beginning on page 5 of these instructions.
6. Never test for gas leaks with an open flame. Use a commercially available soap solution made specifically for the detection of leaks to check all connections, as specified in **Gas Supply and Piping** beginning on page 15 of these instructions.
7. Always install furnace to operate within the furnace's intended temperature-rise range with a duct system which has an external static pressure within the allowable range, as specified in **Temperature Rise** on page 21 of these instructions. See furnace rating plate.
8. When a furnace is installed so that the supply ducts carry air circulated by the furnace to areas outside the space containing the furnace, the return air shall also be handled by duct(s) sealed to the furnace casing and terminating outside the space containing the furnace. See **Circulating Air Supply** on page 15 of these instructions.
9. A gas-fired furnace for installation in a residential garage must be installed as specified in the **Location** section on page 3 of these instructions.
10. The furnace is not to be used for temporary heating of buildings or structures under construction as specified in the **Location** section on page 3 of these instructions.

### WARNING

In the State of Massachusetts:

This product must be installed by a licensed Plumber or Gas Fitter. When flexible connectors are used, the maximum length shall not exceed 36". When lever-type gas shutoffs are used, they shall be T-handle type.

## INSTALLATION

**These instructions must be placed on or near the furnace in a conspicuous place.**

The furnace design is certified by CSA International as a Category IV furnace in compliance with the latest edition of American National Standard Z21.47/CSA Standard 2.3 for Gas-Fired Central Furnaces, for operation with natural gas or propane. Consult the rating plate on the furnace for gas type before installing.

The maximum hourly heat loss of space shall be calculated in accordance with the procedure described in the current manuals of Air Conditioning Contractors of America, or by any other recognized method which is suitable for local conditions, provided the results obtained are in substantial agreement with, and not less than, those obtained using the procedure described in the manuals.

G1D91BU, G1D93BU, and CG90UB models shall be installed only as **upflow** furnaces. G1D93BC and CG90CB models shall be installed only as **counterflow** (downflow) furnaces.

### Inspection of Shipment

**This furnace is shipped in one package, completely assembled and wired.** The thermostat is shipped in a separate carton when ordered.

Upon receipt of equipment, carefully inspect it for possible shipping damage. If damage is found, it should be noted on the carrier's freight bill. Damage claims should be filed with the carrier immediately. Claims of shortages should be filed with the seller within 5 days.

### Location

To provide proper operation and satisfactory performance, care must be taken in choosing the location for this furnace. The atmosphere in which the furnace operates must be free of contaminants such as chlorides and sulfates.

The furnace must be installed so that electrical components are protected from water. **Unit must be level for proper condensate drainage.**

### ⚠ CAUTION

The condensate drain on this furnace is incorporated within the furnace and must be primed before start-up. **The condensate system must not be exposed to temperatures under 32°F.** Use of heat tape is permissible provided the rate temperature of the tape **does not exceed 155°F.**

All models are suitable for closet or utility room installation.

The furnace is suitable for installation in buildings constructed on-site. The furnace should be centralized in respect to the heat distribution system as much as practicable. When installed in a utility room, the door should be wide enough to allow the largest part of the furnace to enter, or permit the replacement of another appliance, such as a water heater.

### ⚠ CAUTION

Do not use the furnace as a heater in a building under construction. The furnace can be severely damaged due to the abnormal environment caused by construction. Chlorides from sources such as paint, stain, or varnish; tile and counter cements; adhesives; and foam insulation are abundant in a structure under construction and can be highly corrosive. Low return air temperature can cause condensation in the furnace and other damage that can shorten the life of the unit.

A gas-fired furnace for installation in a residential garage must be installed so the burner(s) and the ignition source are located not less than 18" above the floor. The furnace is to be located or protected to avoid physical damage by vehicles.

**If the furnace is to be installed in an attic or other insulated space, it must be kept free and clear of insulating materials.**

### Clearances

All servicing and cleaning of the furnace can be performed from the front. If installed in a closet or utility room, provide 18" clearance in front for service if the door to the room is not in line with the front of the furnace.

Refer to Table 1 on page 4 for the minimum clearances to combustibles required for construction and proper unit operation.

**Accessibility clearances must take precedence over fire protection clearances.**

Upflow models (G1D91BU, G1D93BU, & CG90UB) may be installed on wood flooring but shall not be installed directly on carpeting, tile, or any other combustible material.

Counterflow models (G1D93BC & CG90CB) are certified for installation on combustible flooring provided a special base assembly is used. (Refer to the **Duct Connection** –

## Minimum Clearances to Combustibles

Unit Sides	0"
Rear of Unit	0"
Front of Unit	2"
Flue Pipe	0"
Plenum Top	1"

**Table 1**

**Counterflow Models** section on page 15 for more information on using the special base assembly.)

When a counterflow unit is installed on a combustible floor, 1" clearance must be provided between the supply duct and the floor.

### Combustion and Ventilation Air

#### **⚠ WARNING**

Insufficient combustion air can cause headaches, nausea, dizziness, or asphyxiation. When considering combustion air requirements, enough air must also be provided to meet the needs of all fuel-burning appliances and exhaust fans.

Adequate provisions for combustion air and ventilation of furnace must be made. Refer to Section 5.3, "Air for Combustion and Ventilation," of the National Fuel Gas Code, ANSI Z223.1/NFPA54 (latest edition), Sections 7.2, 7.3, or 7.4 of CSA B149.1 Natural Gas and Propane Installation Codes (latest editions), or applicable provisions of the local building codes.

#### **⚠ WARNING**

Air openings in the front of the furnace must be kept free of obstructions. Any obstruction may cause improper operation that can result in a fire hazard or carbon monoxide injury.

### Unconfined Space

An unconfined space is defined as "a space whose volume is more than 50 cubic feet per 1000 BTU per hour of the combined input rating of all appliances installed in that space." When a furnace is installed in an unconfined space in a building, it can be assumed that the infiltration will be sufficient to supply the required air. If the furnace is installed in a ventilated attic or crawl space, it is assumed that the infiltration is sufficient to supply the required air. However, in a building of unusually tight construction, additional outdoor air should be provided.

### Confined Space

A confined space is defined as "a space whose volume is less than 50 cubic feet per 1000 BTU per hour of the combined input rating of all appliances installed in that space."

If the furnace is installed in a confined space within the building and combustion air is taken from a heated space, the combustion air and ventilating air must enter and leave the space through two permanent openings of equal area. One opening shall be located within 12" of the ceiling and the other within 12" of the floor, each having a free area of 1 square inch per 1000 BTU/HR of total input rating of all appliances within the space and not less than 100 square inches each.

If the furnace is installed in a space within a building of tight construction, makeup air must be supplied from outdoors. In this case, one opening shall be within 12" of the ceiling and one opening within 12" of the floor. If combustion ducts are vertical, each opening shall have a free area of 1 square inch per 4000 BTU/HR of the total input rating of all appliances within the enclosure. If horizontal combustion ducts are run, 1 square inch per 2000 BTU/HR is required.

### Contaminated Combustion Air

Excessive exposure to contaminated combustion air will result in safety and performance related problems. The recommended source of combustion air is outdoor air. However, the use of indoor air in most applications is acceptable if the following guidelines are followed:

1. If the furnace is installed in a confined space, it is recommended that the necessary combustion air come from the outdoors by way of an attic, crawl space, air duct, or direct opening.
2. If indoor combustion air is used, there must be no exposure to the substances listed in item 5.
3. All provisions for indoor combustion air must meet the requirements for combustion air indicated in the National Fuel Gas Code, ANSI Z223.1/NFPA 54 (latest edition), and/or any applicable local codes. In

Canada, see CSA B149.1, Natural Gas and Propane Installation Codes (latest edition).

4. The following types of installation may require **outdoor air** for combustion, due to chemical exposures:

- Commercial buildings
- Buildings with indoor pools
- Furnaces installed in laundry rooms
- Furnaces installed in hobby or craft rooms
- Furnaces installed near chemical storage areas

5. Exposure to the following substances in the combustion air supply may also require **outdoor air** for combustion:

- Permanent wave solutions
- Chlorinated waxes and cleaners
- Chlorine-based swimming pool chemicals
- Water softening chemicals
- Deicing salts or chemicals
- Carbon tetrachloride
- Halogen-type refrigerants
- Cleaning solvents (such as perchloroethylene)
- Printing inks, paint removers, varnishes, etc.
- Cements and glues
- Antistatic fabric softeners for clothes dryers
- Masonry acid washing materials
- Chlorinated laundry products
- Hydrochloric acid

## Venting

The high efficiency of this furnace is accomplished by the removal of both sensible and latent heat from the flue gases. The removal of latent heat results in the condensation of moisture in the flue gases. This condensation occurs in the secondary heat exchanger and in the vent system. Therefore, this furnace requires special venting considerations and the instructions must be followed to insure proper operation. All venting must be in accordance with the codes having jurisdiction in the area and these instructions.

Upflow models G1D91BU, G1D93BU, and CG90UB and counterflow models G1D93BC and CG90CB can be installed as either direct vent or non-direct vent units. A direct vent (two pipe) installation requires that all the air necessary for combustion be supplied from outside the dwelling through an air intake pipe. A non-direct vent (one pipe) installation uses air from inside the dwelling for combustion.

The furnace is shipped with the air inlet pipe terminated to the top panel for either inside or outside combustion air. An inlet air restrictor plate (see Figure 1) is supplied with this furnace and can be found in the plastic bag containing these Installation Instructions and the User's Information Manual. For installations using inside air for combustion (non-direct vent), attach a 90° elbow (not supplied) to the inlet coupler and install the restrictor plate inside the elbow (see Figures 8 and 9 on page 11 or Figures 13 and 14 on page 13).

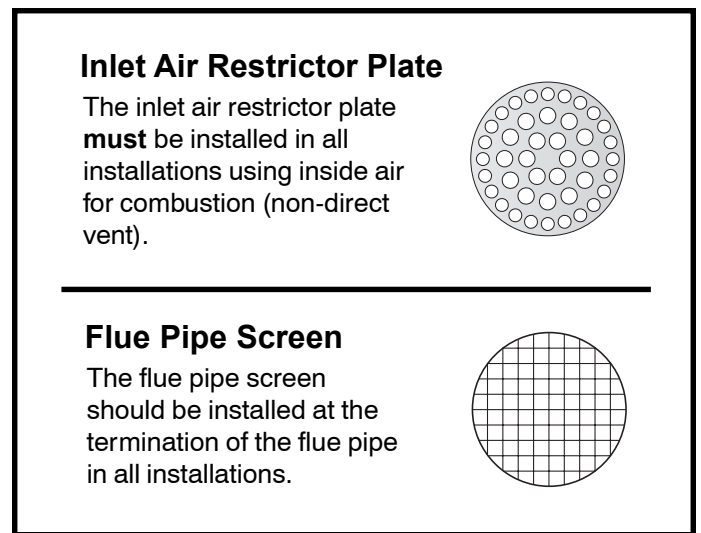


Figure 1

## ⚠ WARNING

If at any time in the future the installation of this furnace is changed to require outside fresh air for combustion, the inlet air restrictor plate must be removed. Failure to remove the inlet air restrictor could cause improper operation that can result in a fire hazard or carbon monoxide injury.

Also included in the plastic bag containing the inlet air restriction plate is a flue pipe screen (see Figure 1). In all installations, this screen should be installed at the termination of the flue pipe and is designed to keep objects out of the flue pipe.

For either type of installation (direct or non-direct vent), special venting considerations must be followed. Refer to the proper section in pages 10 – 13 for the type of furnace and venting being installed.

The venting system must be supported with mounting straps to prevent any weight load from being applied to the vent blower. Horizontal vent pipe must be supported every 5' and vertical pipe should be supported every 10' to prevent sagging and provide rigid support.

When a furnace is installed as direct vent, provisions for ventilation air should follow the same requirements as if installed as non-direct vent. Proper ventilation air is necessary to maintain furnace component temperatures within acceptable limits.

All vents passing through floors, ceilings, and walls must be installed in accordance with National Fuel Gas Code, ANSI Z223.1/NFPA 54 (latest edition).

In all applications where the flue pipe is run through an unconditioned space, 1/2" Armaflex or equivalent must be used over the pipe. In extreme cold climates, 3/4" Armaflex is recommended.

**Materials**

All pipe, fittings, primer, and solvent cement must conform with American National Standard Institute and the American Society for Testing and Materials (ANSI/ASTM) standards. The solvent shall be free flowing and contain no lumps, undissolved particles, or any foreign matter that adversely affects the joint strength or chemical resistance of the cement. The cement shall show no gelation, stratification, or separation that cannot be removed by stirring.

Refer to Table 2 for approved piping and fitting materials.

Piping and Fitting Specifications	
Piping and Fitting Material	ASTM Specification
Schedule 40 PVC (Pipe)	D1785
Schedule 40 PVC (Cellular Core Pipe)	F891
Schedule 40 PVC (Fittings)	D2466
SDR-26 (Pipe)	D2241
Schedule 40 ABS (Pipe)	D1527
Schedule 40 ABS (Fittings)	D2468
Schedule 40 & 80 CPVC (Pipe)	F441
ABS-DWV Drain Waste & Vent (Pipe & Fittings)	D2661
PVC-DWV Drain Waste & Vent (Pipe & Fittings)	D2665

**Table 2**

The primers and solvents used must also meet ASTM specifications. PVC primer is specified in ASTM F656. Use PVC solvent as specified in ASTM D2564 and ABS solvent cement as specified ASTM D2235. Low temperature solvent

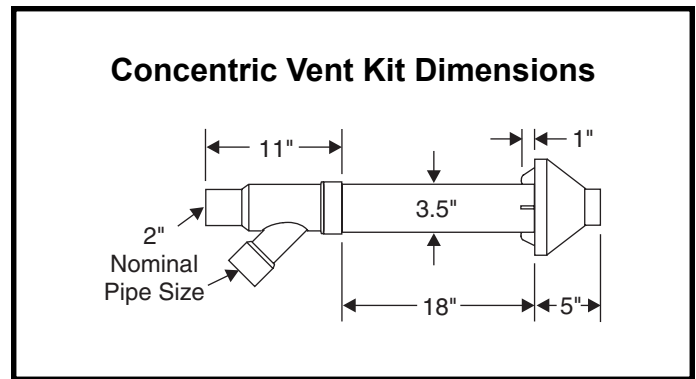
cement is recommended. Metal or plastic strapping may be used for vent pipe hangers.

When making ABS joints, pieces can be prepared with a cleaner. When joining ABS to PVC materials, use PVC solvent cement as specified in ASTM D3138.

Preferred fittings are DWV style or long sweep. Seal all joints gas tight with appropriate cement. In areas where vent and air intake pipes are exposed to abnormal stress or are subject to damage, schedule 80 pipe should be used.

**Concentric Vent Kit**

A concentric vent kit (model ACVK2) is available for use when installing this furnace as a direct vent furnace and the air intake and vent pipe are to be run through the same hole, whether horizontally through the wall or vertically through the roof (see Figure 2). Refer to the instructions included with the concentric vent kit for installation specifics.



**Figure 2**

**Category IV Furnace Limitations**

This furnace shall **not** be connected to any Type B, BW, or L vent or vent connector and shall **not** be connected to any portion of a factory-built or masonry chimney. **This furnace is not to be common vented with any other appliance. The vent pipe must not be connected to a chimney flue serving a separate appliance designed to burn solid fuel.**

**Vent Pipe Size and Length**

The vent pipe and air intake pipe (in direct vent installations) should be sized in accordance with the information found in the appropriate table in Figure 3. One 90° elbow is equivalent to 5' of pipe. Two 45° elbows are equivalent to one 90° elbow. The minimum length certified for use with this furnace is 5' and one elbow, not including the vent and air intake terminals.

In the event that the pipe length is in between the lengths listed in the table, use the next larger length listed. For example, if a length of pipe needed to install the furnace is 27', use the diameter values for the 30' row in the tables.

## Vent Tables

(numbers in inches unless specified otherwise)

### Minimum Pipe Diameter 40,000 – 80,000 BTU/HR Models

Vent Pipe Length (ft.)	Number of 90° Elbows									
	0	1	2	3	4	5	6	7	8	9
5	1.5	1.5	2	2	2	2	2	2	2	2
10	1.5	2	2	2	2	2	2	2	2	2
20	2	2	2	2	2	2	2	2	2	2.5
30	2	2	2	2	2	2	2	2.5	2.5	2.5
40	2	2	2	2	2	2.5	2.5	2.5	2.5	2.5
50	2	2	2.5	2.5	2.5	2.5	2.5	2.5	2.5	3
60	2	2.5	2.5	2.5	2.5	2.5	2.5	3	3	3
70	2.5	2.5	2.5	2.5	2.5	3	3	3	3	NR
80	2.5	2.5	2.5	3	3	3	3	3	NR	NR
90	2.5	2.5	3	3	3	3	3	NR	NR	NR

### Minimum Pipe Diameter 90,000 – 100,000 BTU/HR Models

Vent Pipe Length (ft.)	Number of 90° Elbows									
	0	1	2	3	4	5	6	7	8	9
5	NR	2	2	2	2	2	2	2.5	2.5	2.5
10	2	2	2	2	2	2	2.5	2.5	2.5	2.5
20	2	2	2	2	2	2.5	2.5	2.5	2.5	3
30	2	2	2	2.5	2.5	2.5	2.5	3	3	3
40	2	2	2.5	2.5	2.5	3	3	3	3	3
50	2.5	2.5	2.5	3	3	3	3	3	3	NR
60	2.5	3	3	3	3	3	3	NR	NR	NR
70	3	3	3	3	3	NR	NR	NR	NR	NR
80	3	3	3	NR	NR	NR	NR	NR	NR	NR
90	3	3	NR	NR	NR	NR	NR	NR	NR	NR

### Minimum Pipe Diameter 112,000 – 125,000 BTU/HR Models

Vent Pipe Length (ft.)	Number of 90° Elbows									
	0	1	2	3	4	5	6	7	8	9
5	2.5	2.5	2.5	2.5	2.5	2.5	2.5	2.5	2.5	2.5
10	2.5	2.5	2.5	2.5	2.5	2.5	2.5	2.5	2.5	3
20	2.5	2.5	2.5	2.5	2.5	2.5	2.5	3	3	NR
30	2.5	2.5	2.5	2.5	2.5	3	3	NR	NR	NR
40	2.5	2.5	2.5	2.5	3	NR	NR	NR	NR	NR
50	2.5	3	3	NR	NR	NR	NR	NR	NR	NR
60	3	3	NR	NR	NR	NR	NR	NR	NR	NR

NR = Not Recommended

**Figure 3**

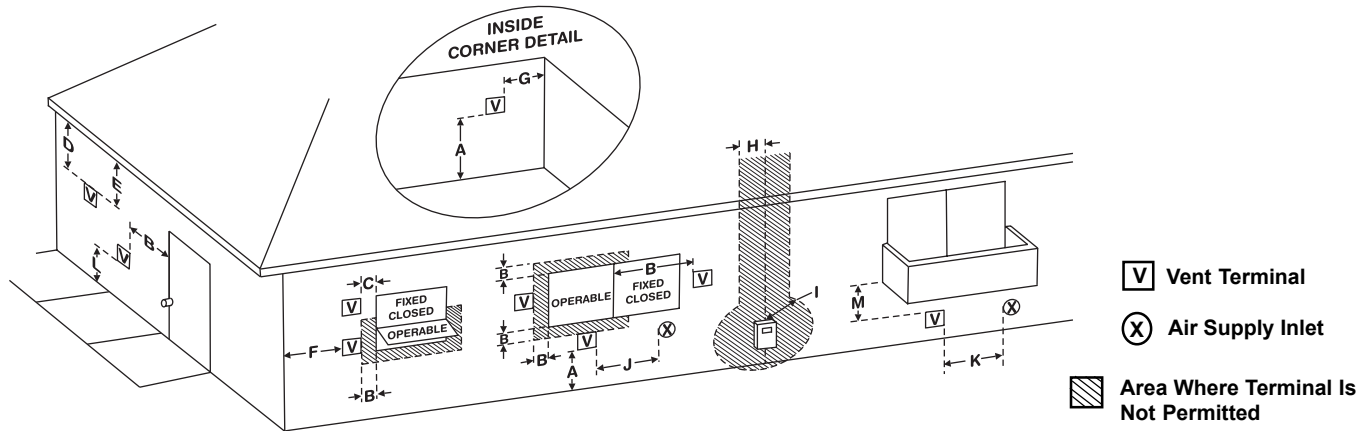
For direct vent installations, if the vent and air intake pipe are not equal in length and number of elbows, then determine the minimum pipe diameter for both the vent and air intake. If the results indicate different diameters, use the larger of the two for both the vent and air intake. **Under no circumstances should the vent and air intake pipe size be different in diameter.** For installation details, refer to the appropriate section in pages 10 – 13 for the unit model and type of installation.

## **Horizontal Venting**

The vent for this appliance shall not terminate over public walkways; or near soffit vents or crawl space vents or other areas where condensate or vapor could create a nuisance or hazard or cause property damage; or where condensate vapor could cause damage or could be detrimental to the operation of regulators, relief valves, or other equipment.

See Figures 4 and 5 on pages 8 and 9 for additional information on where the horizontal vent terminal can and cannot terminate.

## Sidewall Vent Terminal Clearances (Direct Vented Furnaces)



**V** Vent Terminal

**X** Air Supply Inlet

**Hatched Area** Area Where Terminal Is Not Permitted

		Canadian Installations <sup>1</sup>	US Installations <sup>2</sup>
<b>A</b>	Clearance above grade, veranda, porch, deck, or balcony	12 inches (30cm)	12 inches (30cm)
<b>B</b>	Clearance to window or door that may be opened	6 inches (15cm) for appliances ≤ 10,000 Btuh (3 kW), 12 inches (30 cm) for appliances > 10,000 Btuh (3 kW), and ≤ 100,000 Btuh (30 kW), 36 inches (91 cm) for appliances > 100,000 Btuh (30 kW)	6 inches (15 cm) for appliances ≤ 10,000 Btuh (3 kW), 9 inches (23 cm) for appliances > 10,000 Btuh (3 kW), and ≤ 50,000 Btuh (15 kW), 12 inches (30 cm) for appliances > 50,000 Btuh (15 kW)
<b>C</b>	Clearance to permanently closed window	*	*
<b>D</b>	Vertical clearance to ventilated soffit located above the terminal within a horizontal distance of 2 feet (61 cm) from the center line of the terminal	*	*
<b>E</b>	Clearance to unventilated soffit	*	*
<b>F</b>	Clearance to outside corner	*	*
<b>G</b>	Clearance to inside corner	*	*
<b>H</b>	Clearance to each side of center line extended above meter/regulator assembly	3 feet (91 cm) within a height 15 feet (4.5 m) above the meter/regulator assembly	*
<b>I</b>	Clearance to service regulator vent outlet	3 feet (91 cm)	*
<b>J</b>	Clearance to nonmechanical air supply inlet to building or the combustion air inlet to any other appliance	6 inches (15cm) for appliances ≤ 10,000 Btuh (3 kW), 12 inches (30 cm) for appliances > 10,000 Btuh (3 kW), and ≤ 100,000 Btuh (30 kW), 36 inches (91 cm) for appliances > 100,000 Btuh (30 kW)	6 inches (15 cm) for appliances ≤ 10,000 Btuh (3 kW), 9 inches (23 cm) for appliances > 10,000 Btuh (3 kW), and ≤ 50,000 Btuh (15 kW), 12 inches (30 cm) for appliances > 50,000 Btuh (15 kW)
<b>K</b>	Clearance to a mechanical air supply inlet	6 feet (1.83 m)	3 feet (91 cm) above if within 10 feet (3 m) horizontally
<b>L</b>	Clearance above paved sidewalk or paved driveway located on public property	7 feet (2.13 m) <sup>†</sup>	*
<b>M</b>	Clearance under veranda, porch, deck, or balcony	12 inches (30 cm) <sup>‡</sup>	*

<sup>1</sup> In accordance with the current *CSA B149.1, Natural Gas and Propane Installation Code*

<sup>2</sup> In accordance with the current *ANSI Z2223.1/NFPA 54, National Fuel Gas Code*

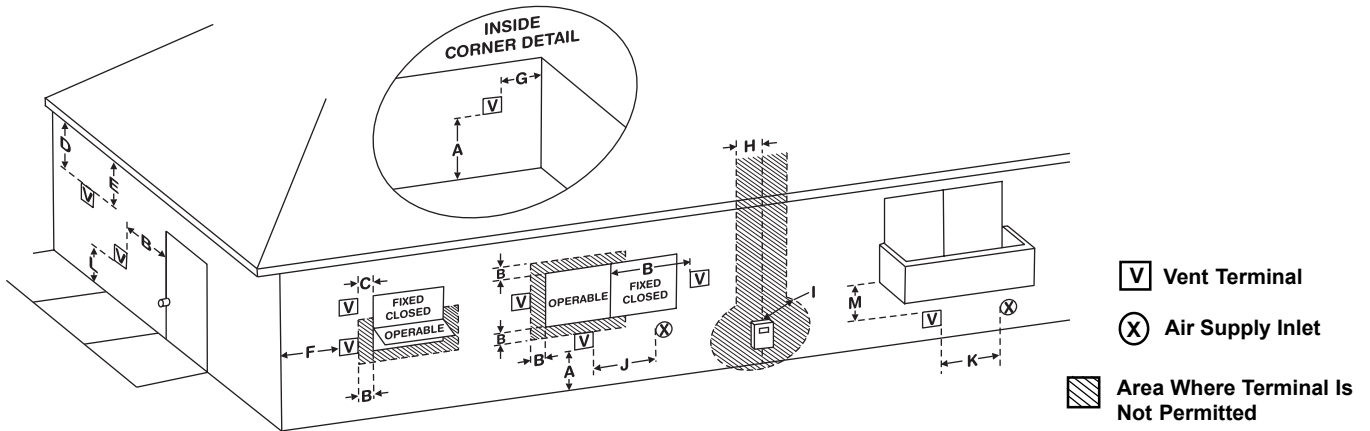
<sup>†</sup> A vent shall not terminate directly above a sidewalk or paved driveway that is located between two single family dwellings and serves both dwellings.

<sup>‡</sup> Permitted only if veranda, porch, deck, or balcony is fully open on a minimum of two sides beneath the floor.

\* For clearances not specified in *ANSI Z2223.1/NFPA 54* or *CSA B149.1*, the following statement shall be included: "Clearance in accordance with local installation codes and the requirements of the gas supplier and the manufacturer's installation instructions."



## Sidewall Vent Terminal Clearances (Non-Direct Vented Furnaces)



- V Vent Terminal
- X Air Supply Inlet
- Area Where Terminal Is Not Permitted

		Canadian Installations <sup>1</sup>	US Installations <sup>2</sup>
<b>A</b>	Clearance above grade, veranda, porch, deck, or balcony	12 inches (30cm)	12 inches (30cm)
<b>B</b>	Clearance to window or door that may be opened	6 inches (15cm) for appliances ≤ 10,000 Btuh (3 kW), 12 inches (30 cm) for appliances > 10,000 Btuh (3 kW), and ≤ 100,000 Btuh (30 kW), 36 inches (91 cm) for appliances > 100,000 Btuh (30 kW)	4 feet (1.2 m) below or to side of opening; 1 foot (300 m) above opening
<b>C</b>	Clearance to permanently closed window	*	*
<b>D</b>	Vertical clearance to ventilated soffit located above the terminal within a horizontal distance of 2 feet (61 cm) from the center line of the terminal	*	*
<b>E</b>	Clearance to unventilated soffit	*	*
<b>F</b>	Clearance to outside corner	*	*
<b>G</b>	Clearance to inside corner	*	*
<b>H</b>	Clearance to each side of center line extended above meter/regulator assembly	3 feet (91 cm) within a height 15 feet (4.5 m) above the meter/regulator assembly	*
<b>I</b>	Clearance to service regulator vent outlet	3 feet (91 cm)	*
<b>J</b>	Clearance to nonmechanical air supply inlet to building or the combustion air inlet to any other appliance	6 inches (15cm) for appliances ≤ 10,000 Btuh (3 kW), 12 inches (30 cm) for appliances > 10,000 Btuh (3 kW), and ≤ 100,000 Btuh (30 kW), 36 inches (91 cm) for appliances > 100,000 Btuh (30 kW)	4 feet (1.2 m) below or to side of opening; 1 foot (300 m) above opening
<b>K</b>	Clearance to a mechanical air supply inlet	6 feet (1.83 m)	3 feet (91 cm) above if within 10 feet (3 m) horizontally
<b>L</b>	Clearance above paved sidewalk or paved driveway located on public property	7 feet (2.13 m) <sup>†</sup>	7 feet (2.13 m)
<b>M</b>	Clearance under veranda, porch, deck, or balcony	12 inches (30 cm) <sup>‡</sup>	*

<sup>1</sup> In accordance with the current *CSA B149.1, Natural Gas and Propane Installation Code*

<sup>2</sup> In accordance with the current *ANSI Z2223.1/NFPA 54, National Fuel Gas Code*

<sup>†</sup> A vent shall not terminate directly above a sidewalk or paved driveway that is located between two single family dwellings and serves both dwellings.

<sup>‡</sup> Permitted only if veranda, porch, deck, or balcony is fully open on a minimum of two sides beneath the floor.

\* For clearances not specified in *ANSI Z2223.1/NFPA 54* or *CSA B149.1*, the following statement shall be included: "Clearance in accordance with local installation codes and the requirements of the gas supplier and the manufacturer's installation instructions."

**Upflow Models G1D91BU, G1D93BU, & CG90UB  
Direct Vent Installation**

An inlet air restrictor plate (see Figure 1 on page 5) is supplied with this furnace and can be found in the plastic bag containing these Installation Instructions and the User's Information Manual. **This restrictor plate is to be used only in non-direct vent applications.** See the non-direct venting sections on pages 11 and 13 for more information on installing the restrictor plate in non-direct vent applications.

The flue pipe screen (see Figure 1 on page 5) should be installed at the termination of the flue pipe and is designed to keep objects out of the flue pipe. An additional screen should **not** be placed in the intake termination. If a screen is installed, the air intake may freeze shut.

Prime the trap system by slowly pouring 1 cup of water down the vent pipe.

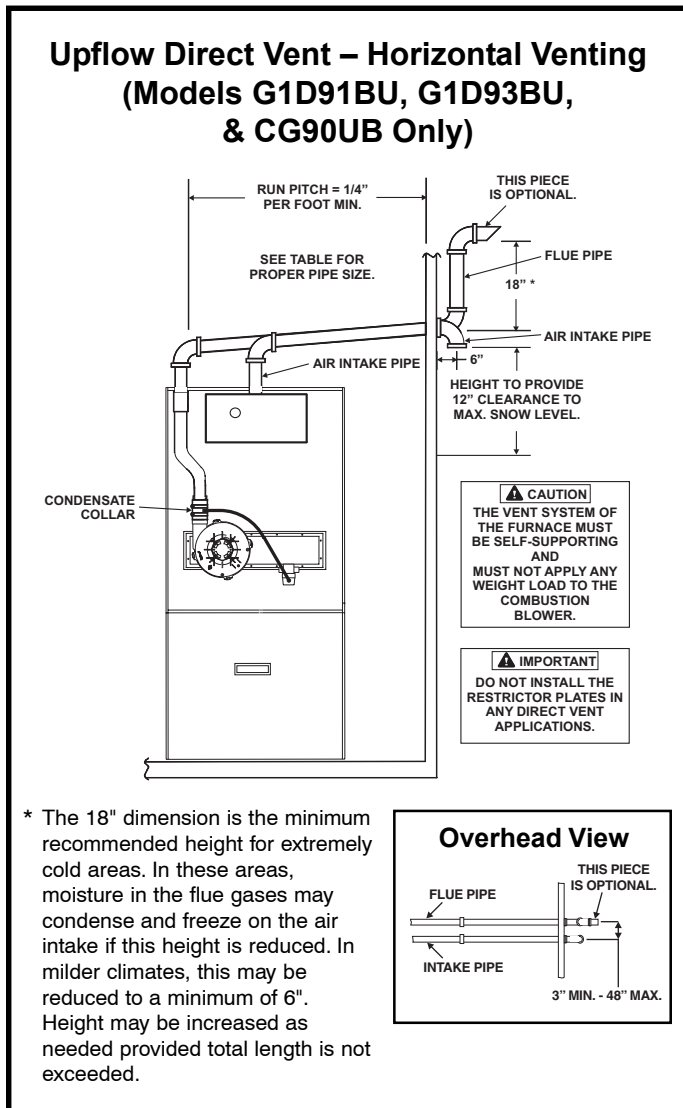
For horizontal venting, refer to Figure 6. For vertical venting, refer to Figure 7. The vent pipe on horizontal runs must

slope upward, away from the furnace, at a minimum pitch of 1/4" per foot of run, to prevent accumulation of condensate.

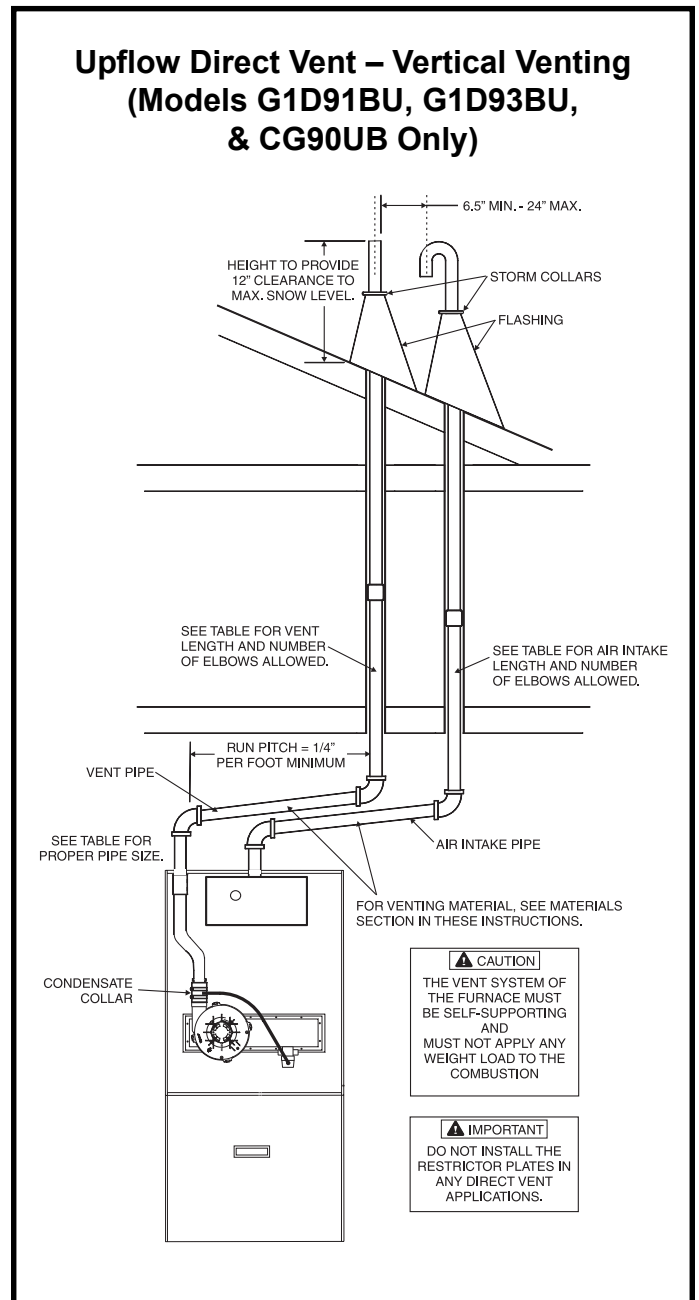
**Do not cement air intake into the connector on burner box. Use high temperature RTV silicone sealant so intake pipe can be removed if service is required.**

**For proper operation, the vent and air intake pipe must be installed in the same pressure zone. Therefore, in horizontal venting applications they must be on the same side of the house within the parameters shown in Figure 6.**

On initial start-up of the unit, some of the water used to prime the trap system may run down into the combustion blower and cause noise.



**Figure 6**



**Figure 7**

**Upflow Models G1D91BU, G1D93BU, & CG90UB  
Non-Direct Vent Installation**

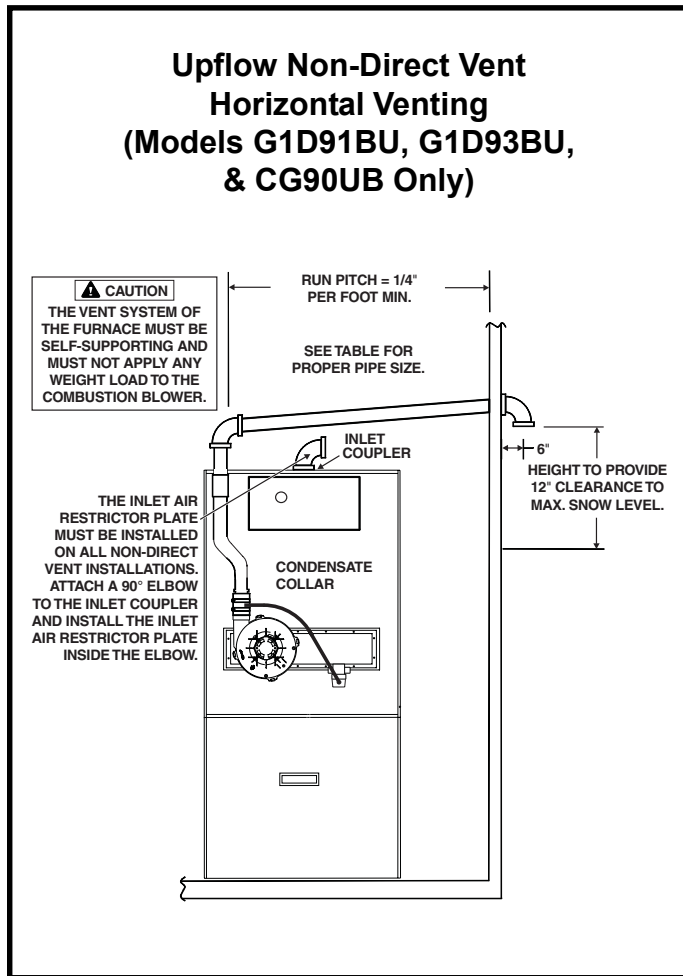
An inlet air restrictor plate (see Figure 1 on page 5) is supplied with this furnace and can be found in the plastic bag containing these Installation Instructions and the User's Information Manual. This restrictor plate is to be used only in non-direct vent applications. Attach a 90° elbow (not supplied) to the inlet coupler and install the restrictor plate inside the elbow in all non-direct vent installations (see Figures 8 and 9).

The flue pipe screen (see Figure 1 on page 5) should be installed at the termination of the flue pipe and is designed to keep objects out of the flue pipe.

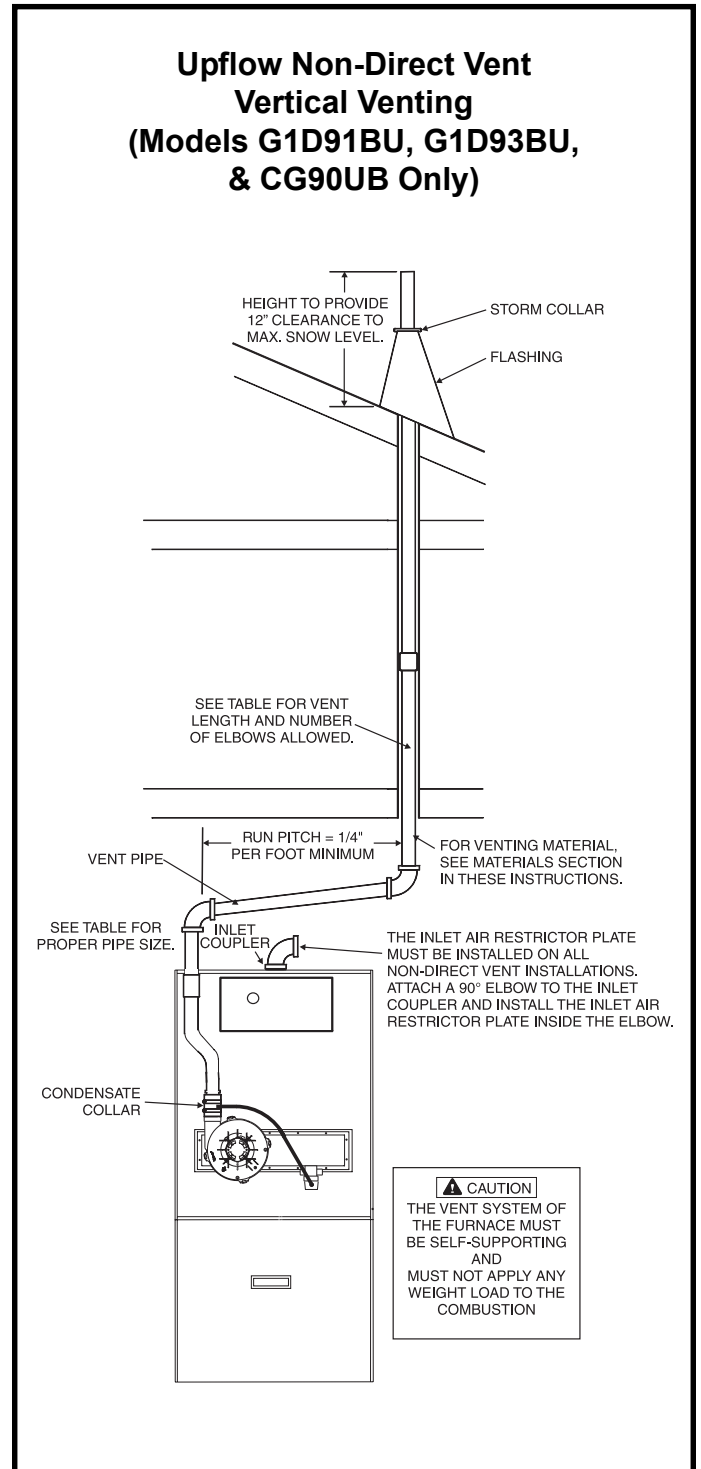
Prime the trap system by slowly pouring 1 cup of water down the vent pipe.

For horizontal venting, refer to Figure 8. For vertical venting, refer to Figure 9. The vent pipe on horizontal runs must slope upward, away from the furnace, at a minimum pitch of 1/4" per foot of run, to prevent accumulation of condensate.

On initial start-up of the unit, some of the water used to prime the trap system may run down into the combustion blower and cause noise.

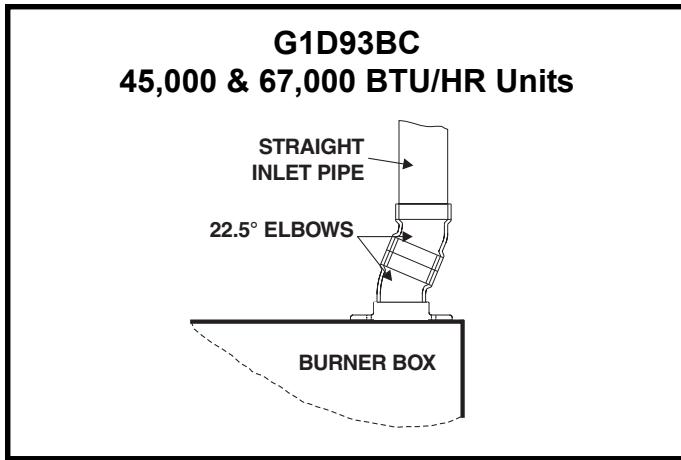


**Figure 8**



**Figure 9**

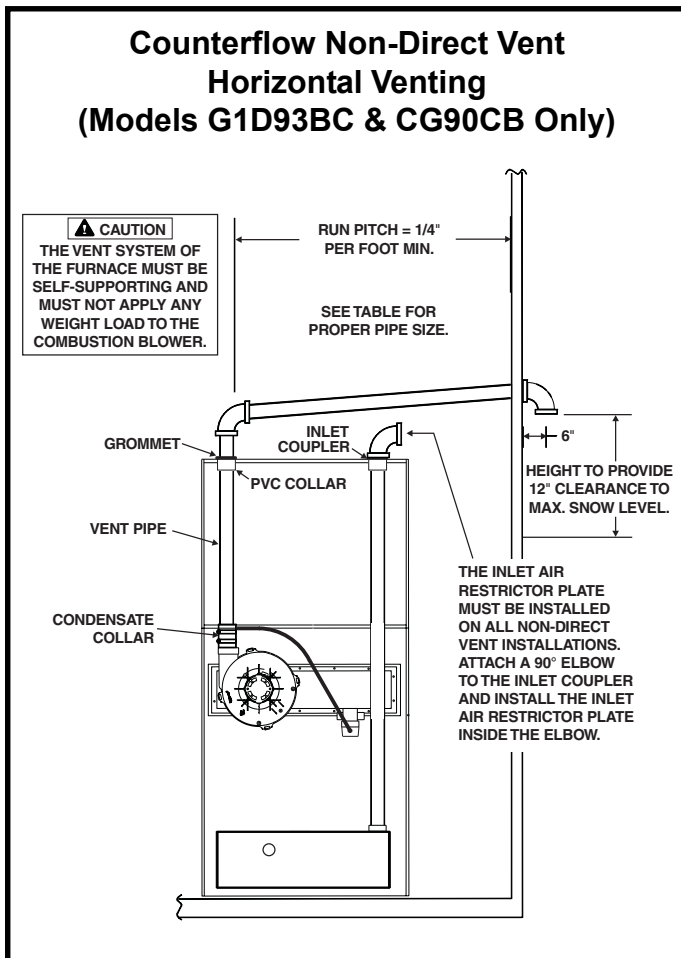




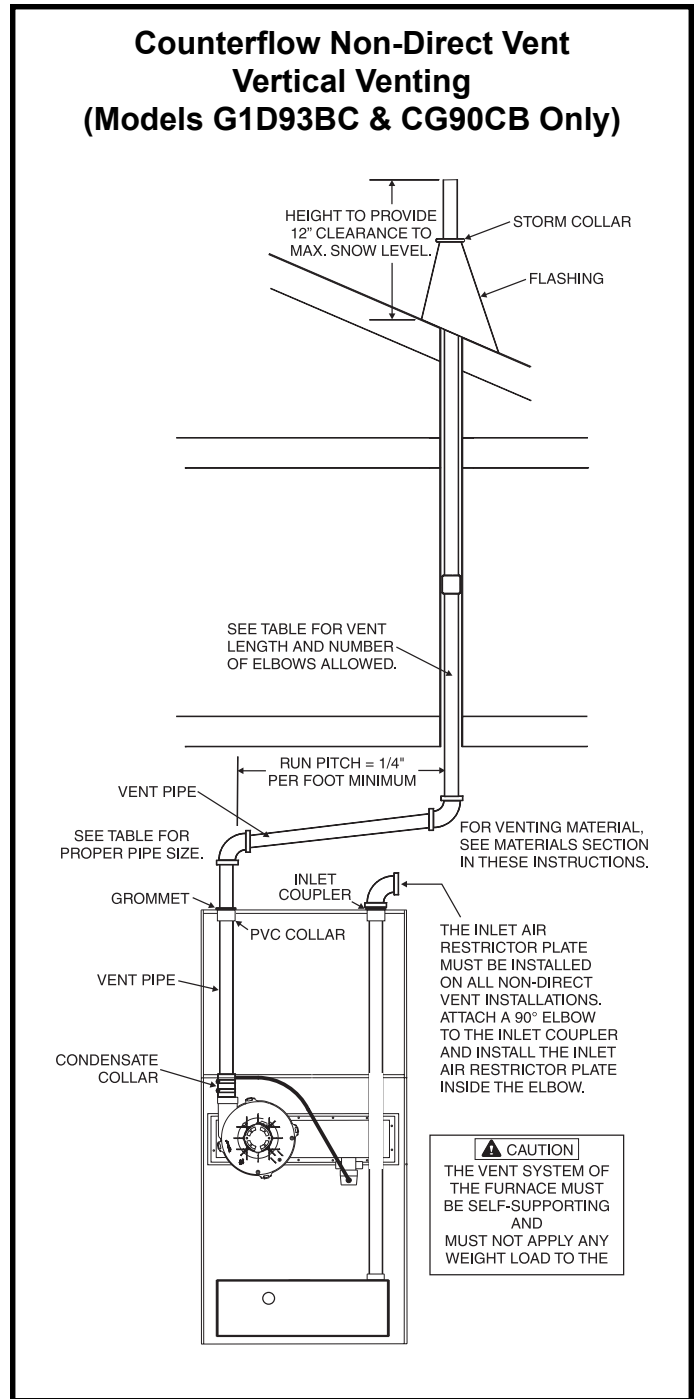
**Figure 12**

**Counterflow Models G1D93BC & CG90CB Non-Direct Vent Installation**

An inlet air restrictor plate (see Figure 1 on page 5) is supplied with this furnace and can be found in the plastic bag containing these Installation Instructions and the User's Information Manual. This restrictor plate is to be used only in non-direct vent applications. Attach a 90° elbow (not supplied) to the inlet coupler and install the restrictor plate inside the elbow in all non-direct vent installations (see Figures 13 and 14).



**Figure 13**



**Figure 14**

The flue pipe screen (see Figure 1 on page 5) should be installed at the termination of the flue pipe and is designed to keep objects out of the flue pipe.

Prime the trap system by slowly pouring 1 cup of water down the vent pipe. For horizontal venting, refer to Figure 13. For vertical venting, refer to Figure 14. The vent pipe on horizontal runs must slope upward, away from the furnace, at a minimum pitch of 1/4" per foot of run, to prevent accumulation of condensate.

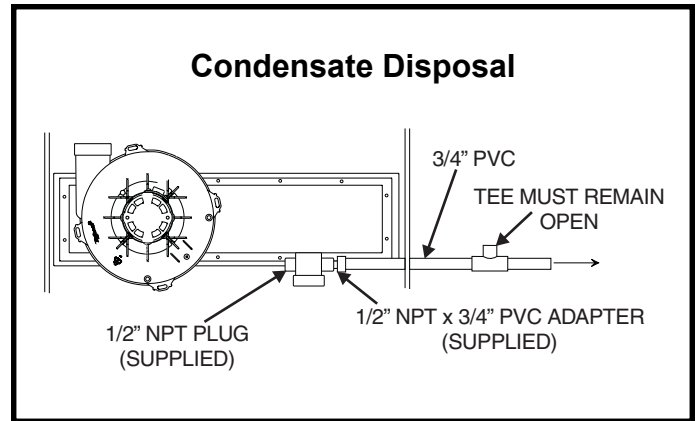
On initial start-up of the unit, some of the water used to prime the trap system may run down into the combustion blower and cause noise.

## Existing Venting Systems

When an existing furnace is removed or replaced, the original venting system may no longer be sized to properly vent the attached appliances. An improperly sized venting system can result in spillage of flue products into the living space, the formation of condensate, leakage, etc. See the **WARNING** box below for proper test procedure.

## Condensate Disposal Installation

Install the condensate drain line to the unit as follows. The condensate can be drained from either the right or left side of the furnace. Install the 1/2" NPT x 3/4" PVC adapter (supplied) in the drain on the side that the draining will occur. Install the plastic pipe plug opposite of the drain. Using 3/4" PVC pipe, make a connection from the adapter just installed to extend just outside the unit. Install a 3/4" PVC tee as shown in Figure 15. From the tee, install the drain to the disposal area. The top of the tee must be left open for proper condensate drainage.



**Figure 15**

It is recommended that the condensate drain be routed directly to a locally acceptable disposal area. The condensate drain line should not be run directly to the outdoors especially in colder climates where temperatures may cause the condensate to freeze in the drain line.



## CARBON MONOXIDE POISONING HAZARD

Failure to follow the steps outlined below for each appliance connected to the venting system being placed into operation could result in carbon monoxide poisoning or death.

The following steps shall be followed for each appliance connected to the venting system being placed into operation, while all other appliances connected to the common venting system are not in operation:

1. Seal any unused openings in the common venting system.
2. Visually inspect the venting system for proper size and horizontal pitch, as required in the National Fuel Gas Code, ANSI Z223.1/NFPA 54 (latest edition) or the CSA B149.1 Natural Gas and Propane Installation Codes and these instructions. Determine that there is no blockage or restriction, leakage, corrosion, or other deficiencies which could cause an unsafe condition.
3. As far as practical, close all building doors and windows between the space in which the appliance(s) connected to the venting system are located and other spaces in the building.
4. Close fireplace dampers.
5. Turn on clothes dryers and any appliance not connected to the venting system. Turn on any exhaust fans, such as range hoods and bathroom exhausts, so they are operating at maximum speed. Do not operate a summer exhaust fan.
6. Follow the lighting instructions. Place the unit being inspected in operation. Adjust the thermostat so appliance is operating continuously.
7. Test for spillage from draft hood equipped appliances at the draft hood relief opening after 5 minutes of main burner operation. Use the flame of a match or candle.
8. If improper venting is observed during any of the above tests, the venting system must be corrected in accordance with the National Fuel Gas Code, ANSI Z223.1/NFPA 54 (latest edition) and/or the CSA B149.1 Natural Gas and Propane Installation Codes.
9. After it has been determined that each appliance remaining connected to the venting system properly vents when tested as outlined above, return doors, windows, exhaust fans, fireplace dampers, and any other gas-fired burning appliance to their previous conditions of use.

## Circulating Air Supply

When the furnace is installed so that the supply ducts carry air circulated by the furnace to areas outside the space containing the furnace, the return air shall be handled by a duct or ducts sealed to the furnace casing and terminated outside the space containing the furnace.

A return air duct system is recommended. If the unit is installed in a confined space or closet, a return connection must be run, full size, to a location outside the closet. The air duct in the closet must be tight to prevent any entrance of air from the closet into the circulating air.

If there is no complete return air duct system, the return air connection must be sealed to the furnace casing and run, full size, to a location outside the utility room or space housing the furnace to prevent a negative pressure on the venting system.

### **CAUTION**

When an air conditioning unit is used in conjunction with the furnace, the evaporator coil must be installed in the discharge (supply) air. Do not install an evaporator coil in the return air; excessive condensation will occur within the furnace.

## Outlet Duct

For installations not equipped with a cooling coil, a removable access panel must be provided in the outlet duct. The opening should be accessible when the furnace is placed in service. Smoke or reflected light may be observed inside the casing to indicate the presence of leaks in the heat exchanger. The cover for the opening shall be attached in such a manner as to prevent leaks. The recommended opening size is 6" x 14" for all sizes.

## Duct Connection – Counterflow Models

If a unit is installed on a noncombustible floor, it may be installed directly over the supply duct or plenum. For installations on combustible flooring, a special base must be ordered and used. (See the **Accessories** section on page 24 for more information.) To install using the special base assembly, see Figure 16 and the following instructions:

1. Cut a hole in the floor, sized to provide 1" clearance between all four sides of the duct and the edge of the flooring. The four angles on the base assembly should recess into the floor joists and the base should rest on all four outside flanges.
2. Construct duct connections with right angle flanges.

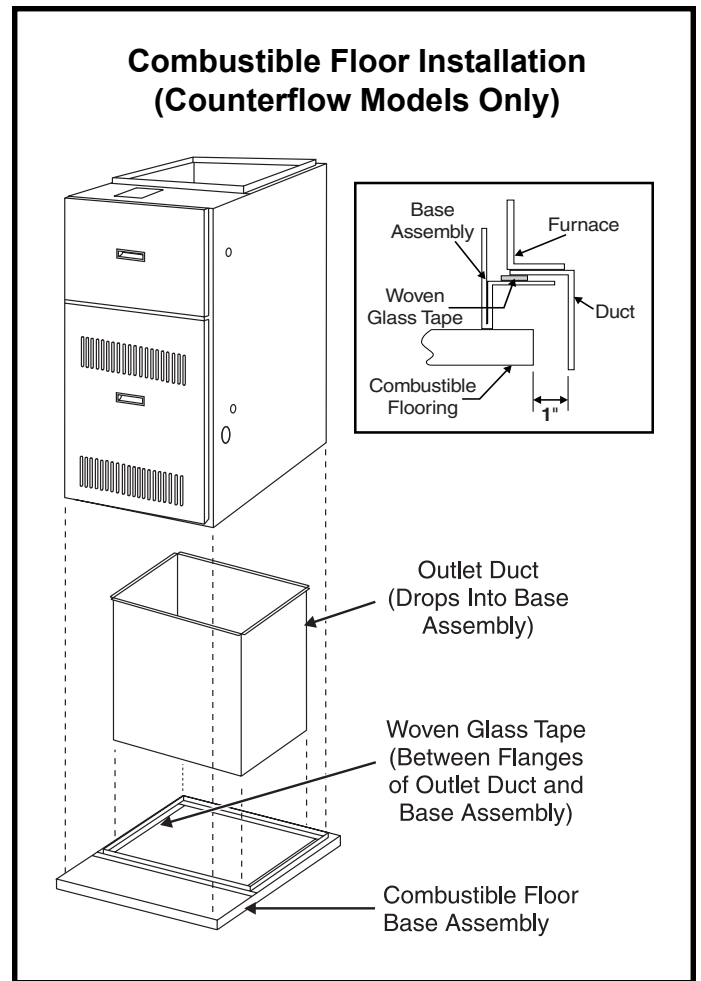


Figure 16

3. Drop the duct connections through the top of the base assembly with the right angle flanges in good contact with the glass tape on top of the base assembly.
4. Carefully position the furnace over the right angle duct flanges.

## Gas Supply and Piping

Refer to the furnace rating plate to make sure the furnace is equipped to burn the gas supplied (natural or propane).

### **WARNING**

Any conversion of a natural gas unit to propane gas must be done by qualified personnel using a conversion kit available from the manufacturer, following the instructions in the conversion kit. If done improperly, overfiring of the burners and improper burner operation can result. This can create carbon monoxide which could cause asphyxiation.

Gas supply piping should be installed in accordance with local codes and the regulations of the utility. Piping must be of adequate size to prevent undue pressure drop. Consult the local utility or gas supplier for complete details on special requirements for sizing gas piping.

If local codes allow the use of a flexible gas appliance connector, always use a new listed connector. Do not use a connector which has previously serviced another gas appliance.

Pipe connections must be tight, and a non-hardening pipe compound resistant to liquefied petroleum gases should be used.

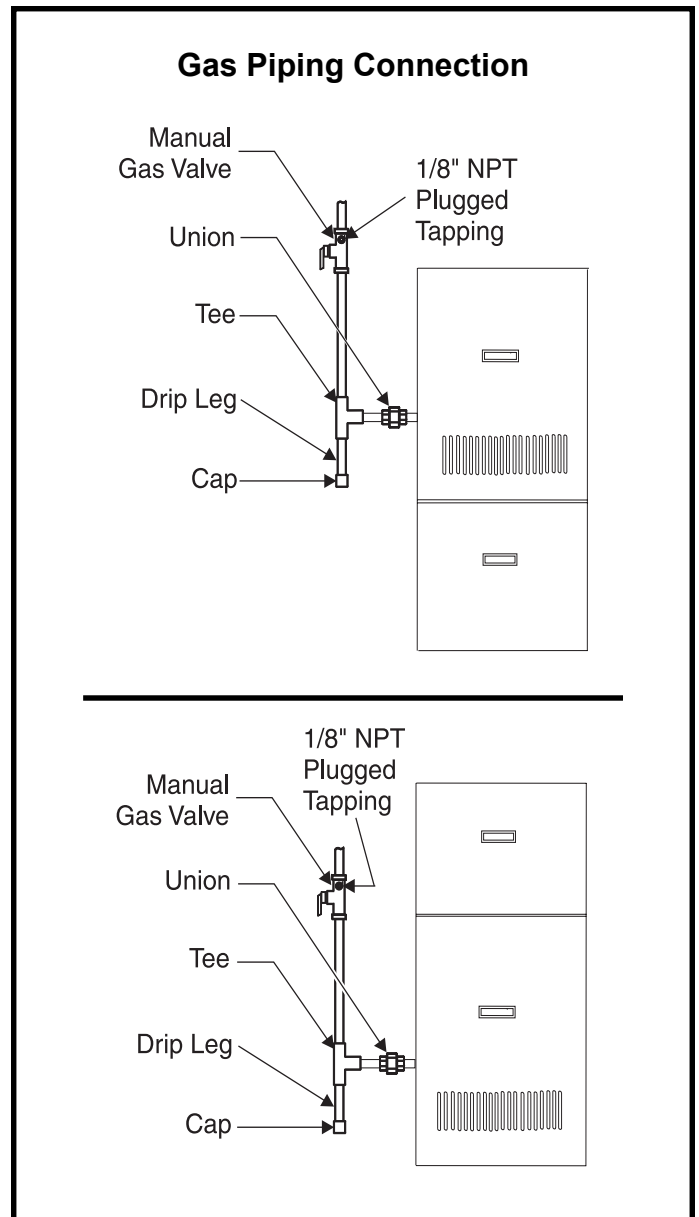
Connect the gas pipe to the furnace controls providing a ground joint union as close to the controls as is possible to facilitate removal of controls and manifold. Provide a drip leg on the outside of the furnace. A manual shutoff valve shall be installed in the gas line, outside the unit, 5' above the floor, or in accordance with any local codes. A test gauge connection must be installed with a 1/8" NPT plugged tapping immediately upstream of the shutoff valve (refer to Figure 17).

The furnace must be isolated from the gas supply piping system by closing the individual manual shutoff valve during any pressure testing of the gas supply piping system at test pressure equal to or less than 1/2 psig (3.5 kPa) or 14" W.C. If the piping system is to be tested at pressures in excess of 1/2 psig (3.5 kPa), the furnace and its appliance main gas valve must be disconnected from the gas supply piping system.

**⚠ WARNING**

The gas valve supplied with this furnace is rated at 1/2 psig maximum. Any higher pressure may rupture the pressure regulator diaphragm and may cause overfiring of the burners and improper burner operation. The overfiring may result in the creation of carbon monoxide which could cause asphyxiation.

After gas piping is complete, carefully check all piping connections (factory and field) for gas leaks. Use a leak detecting solution or other preferred means. Some soaps used for leak detection are corrosive to certain metals. Carefully rinse piping thoroughly after leak detection has been completed.



**Figure 17**

**⚠ WARNING**

**FIRE OR EXPLOSION HAZARD**

Failure to follow the safety warnings exactly could result in serious injury, death, or property damage.

Never test for gas leaks with an open flame. Use a commercially available soap solution made specifically for the detection of leaks to check all connections. A fire or explosion may result causing property damage, personal injury, or loss of life.



## Electrical Wiring

### **⚠ WARNING**

Risk of electrical shock. Disconnect electrical power at the circuit breaker or service panel before making electrical connections. Failure to disconnect power supplies can result in property damage, personal injury, or death.

The furnace must be grounded and wired in accordance with local codes or, in the absence of local codes, with the National Electrical Code ANSI/NFPA No. 70 (latest edition) and/or CSA C22.1 Electrical Code (latest edition) if an external electrical source is utilized.

In all instances, other than wiring for the thermostat, the wiring to be done and any replacement of wire shall conform with the temperature limitation for Type T wire – 63°F (35°C) rise.

Connect a sufficiently sized wire with ground to the furnace's line voltage connections and ground lug. Refer to the furnace rating plate for electrical characteristics to be used in sizing field supply wiring and over-current protection.

The line voltage supply should be routed through a readily accessible disconnect located within sight of the furnace. A junction box on the furnace side panel is provided for line voltage connections. Refer to the furnace wiring diagram for specific connection information.

**Proper polarity of the supply connections (“HOT” and “NEUTRAL”) must be observed to ensure that safety controls provide the protection intended.**

A connection to the ground lug and actual earth ground (typically a ground stake or buried steel pipe) must be maintained for proper operation.

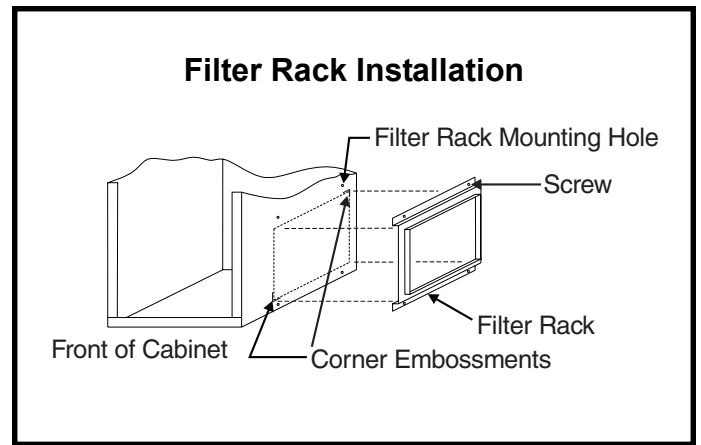
### **Filters**

**Filters are not supplied with CG90CB or CG90UB series furnaces.**

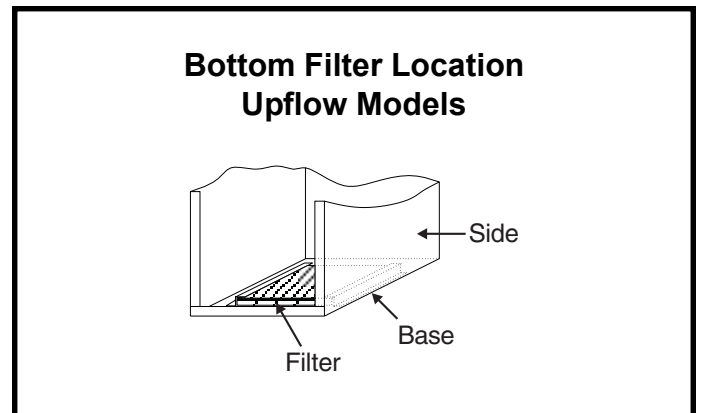
#### ***G1D91BU and G1D93BU Models***

A filter rack and cleanable 16" x 25" x 1/2" filter are supplied with the furnace. (Models designed for more than 1600 CFM nominal air delivery include two of each.) The filter rack is to be installed between the return air duct and the side of the furnace. Refer to Figure 18 and the following instructions to install the filter rack:

1. Using the corner embossments as a guide, mark and cut a full-size opening in the side panel(s).



**Figure 18**



**Figure 19**

2. Using the filter rack as a template, mark and drill four 7/64" diameter screw holes in the side panel(s).
3. With the filter access opening toward the front of the furnace, use sheet metal screws to fasten the rack(s) to the side panel(s).

The filter slides in the rack from the front of the unit. Install the filter(s) with the mesh side towards furnace.

For units that do not include a side return filter rack, kit AFILT524 can be used. Single side filter frame kit AFILTHA7 is available for single side return air connection in installations requiring more than 1600 CFM nominal air delivery. Bottom return filter kit AFILT529 is also available from the manufacturer.

#### **Counterflow Models:**

Filters are not supplied with these furnaces; however, filters must be used. It is the installer's responsibility to install properly sized filters in accordance with Table 3 on page 18.

Other filter accessories are also available from the manufacturer including a full line of indoor air quality products. For information on these products, contact the local distributor.

## Minimum Filter Requirements

Airflow Descriptor	Disposable Filters			Cleanable Filters		
	Min. Area (sq. in.)	Size (in.)	Qty.	Min. Area (sq. in.)	Size (in.)	Qty.
09	480	20 x 25	1	240	16 x 20	1
10	480	20 x 25	1	240	16 x 20	1
12	576	16 x 20	2	288	16 x 20	1
14	672	20 x 20	2	336	20 x 20	1
16	768	20 x 20	2	384	20 x 20	1
20	960	20 x 25	2	480	20 x 25	1

1. The Airflow Descriptor is the two digits following the "D" in the model number.
2. Areas and dimensions shown for cleanable filters are based on filters rated at 600 feet per minute face velocity.
3. Typical filter sizes are shown; however, any combination of filters whose area equals or exceeds the minimum area shown is satisfactory.

**Table 3**

### Thermostat

Install a room thermostat according to the instructions furnished with it. Select a location on an inside wall that is not subject to drafts, direct sunshine, or other heat sources. The initial heat anticipator setting should be equal to the total current draw of the control circuit.

Low voltage thermostat connections are to be made to the blower control board as indicated on the wiring diagram.

### Humidifier

Terminals are provided on the blower control board for connection to a 120-volt humidifier. The "HUM" terminal is energized whenever the thermostat calls for heat. Refer to furnace wiring diagram for specific connection information.

### Continuous Low Speed Blower

If continuous blower operation on low speed is desired, connect the lowest speed motor tap to the "CONT" terminal on the blower control board (refer to the furnace wiring diagram.) The blower will operate on low speed whenever main power is connected to the furnace, except when it operates on heating or cooling speed during thermostat call for heat or cooling. **This constant air terminal is intended for low speed only.** If a motor is wired for a higher speed, the increased amp draw could cause the board control to fail and void the warranty.

### Electronic Air Cleaner

Terminals are provided on the blower control board for connection of a 120-volt electronic air cleaner. The "EAC" terminal is energized whenever the thermostat is calling for heat, cooling, or continuous blower. Refer to the furnace wiring diagram for specific connection information.

### Twinning

The blower control board is designed to permit "twinning" of furnaces (two furnaces connected to a common supply and return air system, and controlled by one thermostat). An accessory kit must be ordered from the manufacturer. Specific wiring and operating instructions are included with the kit.

**Each furnace must have its own dedicated vent system.**

## START-UP

### Lighting Instructions

For Your Safety, Read Before Operating

#### **⚠ WARNING**

If you do not follow these instructions exactly, a fire or explosion may result causing property damage, personal injury, or loss of life.

These furnaces are equipped with an ignition device which automatically lights the burners. **Do not try to light the burners by hand.**

**Before operating**, smell all around the appliance area for gas. Be sure to smell next to the floor because some gas is heavier than air and will settle on the floor.

#### What to do if you smell gas:

- Do not try to light any appliances.
- Extinguish any open flame.
- Do not touch any electric switch; do not use any phone in your building.
- Immediately call your gas supplier from a neighbor's phone. Follow the gas supplier's instructions.
- If you cannot reach your gas supplier, call the fire department.

Do not use this furnace if any part has been under water. Immediately call a qualified service technician to inspect the furnace and to replace any part of the control system and gas control which has been under water.

**IMPORTANT: Refer to the Lighting Instruction label on the furnace for instructions on operating the specific controls used on your unit.**

### To Start Furnace:

#### **⚠ CAUTION**

Be sure the manual gas control has been in the "OFF" position for at least 5 minutes before starting the unit. Do not attempt to manually light the burners.

1. Set the room thermostat to lowest setting.
2. Remove burner access door.
3. Move the gas control knob to the "ON" position. Use only your hand to turn the gas control knob; never use tools. If the knob will not turn by hand, don't try to repair it; call a qualified service technician. **Force or attempted repair may result in a fire or explosion.**
4. Replace the burner access door.
5. Turn on the electrical power to the furnace.
6. Set the room thermostat to a point above room temperature to light the main burners. After the burners have ignited, set the room thermostat to desired temperature.

### To Shut Down Furnace:

1. Set the room thermostat to the lowest setting.
2. Turn off all electric power to the furnace.
3. Remove burner access door.
4. Shut off the gas by moving the gas control knob to the "OFF" position.
5. Replace the burner access door.

#### **⚠ WARNING**

Should overheating occur or the gas supply fail to shut off, shut off the manual gas valve to the appliance before shutting off the electrical supply.

## OPERATION

### Sequence of Operation

#### **Heating**

During a call for heat the thermostat closes the R-W circuit of the control board. The control board verifies limit switches are closed and pressure switch is open. The induced draft blower relay closes causing the blower to run. As vent pressure is developed by the induced draft blower, the pressure switch closes. After a 15-second pre-purge, the control energizes the hot surface ignitor. After the 7-second warmup time, the control energizes the main gas valve causing the main burners to ignite. The hot surface ignitor is de-energized 3 seconds after the main valve opens. If flame is sensed during this time the main valve remains energized and the control starts the 30-second heat blower "on" delay.

As heating demand is met, the thermostat de-energizes the R-W circuit. The control de-energizes the main valve causing the burners to shut off. The induced draft blower shuts off after a 15-second post-purge delay. The circulating air blower will continue to operate until the user-selectable heat blower "off" delay expires. The control return to standby mode once the heat blower "off" delay expires.

#### **Fan "On"**

During a fan "on" call, the thermostat energizes the R-G circuit of the control board, immediately causing the fan to energize the COOL speed. The fan remains energized as long as the thermostat calls for fan "on" operation.

If a call for cooling is energized during a fan "on" call, the fan continues to operate at the COOL speed. If a call for heat is energized during a fan "on" call, the control de-energizes the fan immediately and begins the heat call/ignition sequence.

At the end of the fan "on" call the thermostat de-energizes the R-G circuit of the control, causing the fan to be de-energized immediately.

#### **Cooling**

During a call for cooling, the thermostat energizes the R-Y circuit of the control board. After a 1-second cooling "on" delay, the control energizes the cooling fan speed. If the fan is already energized, it remains running and does not de-energize for the 1-second cooling fan "on" delay.

The call for cooling has priority over continuous fan operation while a call for heating has priority over both a call for cooling or continuous fan. Ignition lockouts for any reason do not affect cooling operation.

As cooling demand is met, the thermostat de-energizes the R-Y circuit of the control board. After a 60-second

cooling "off" delay, the control de-energizes the cooling speed fan. At the end of the cooling "off" delay period, the control returns to the standby mode.

### Controls

Following is a description of the operation of some of the controls used in this furnace. All models use one of each control, except as noted.

#### **Pressure Switch**

The pressure switch is a normally open switch that monitors combustion air flow. Inadequate air flow resulting from excessive venting system restriction or a failed combustion blower will cause the switch to remain open.

#### **Rollout Switch**

The rollout switch is a normally closed switch that opens when abnormal temperatures exist in the burner area. This can be caused by a restricted heat exchanger causing main burner flame to "roll out" into the vestibule area or burner box.

This switch must be manually reset by pushing the button on top to restore furnace operation. G1D93BC units have two rollout switches.

#### **Primary Limit Control**

This is a normally closed control that opens if abnormally high circulating air temperatures occur. It is an automatic reset control.

#### **Auxiliary Limit Control**

This is a normally closed control that opens under abnormal "reverse air flow" conditions that could occur in a counterflow or horizontal installation if the circulating blower fails. It is an automatic reset control.

Upflow models do not include an auxiliary limit control.

#### **Interlock (Blower Door) Switch**

When the blower door is removed, the interlock switch breaks the power supply to the burner controls and blower motor. The switch operation must be checked to confirm it is operating correctly.

#### **Blower Control Board**

The blower control board operates the circulating air blower, the combustion blower and any accessories connected to it. These models feature user-selectable blower "off" delay times (60, 90, 120, and 180 seconds) that are factory set to provide a 120-second blower "off" delay on heating (see wiring diagram on page 26).

Refer to the furnace wiring diagram while using the following procedure to change motor speed:

1. Turn off electrical power to the unit.
2. Connect the desired speed tap for cooling on the blower control board.
3. For heating speed, check the temperature rise and, if necessary, adjust the blower speed tap to maintain temperature rise within the range shown on the furnace rating plate.

To use the same speed tap for both heating and cooling, install a piggyback terminal on the speed tap using a short jumper. Wire 1/4" quick connect terminals on both ends to jumper the "HEAT" and "COOL" speed on the blower control board.

4. The remaining speed taps must be connected to dummy terminals marked "PARK" on the blower control board.

### Checking and Adjusting Gas Input

The minimum permissible gas supply pressure for the purpose of input adjustment is 5" W.C. for natural gas and 11" W.C. for propane gas. This furnace requires conversion for use with propane (see **Accessories** section on page 24 for correct kit). The maximum inlet gas supply pressure is 10.5" W.C. for natural gas and 13" W.C. for propane.

Gas input must never exceed the value shown on the furnace rating plate. The furnace is equipped for rated input at manifold pressures of 3.5" W.C. for natural gas or 10.0" W.C. for propane gas.

To measure the manifold pressure, disconnect the hose and remove the barbed fitting in the downstream side of the gas valve and connect a water manometer or gauge (see Figure 20).

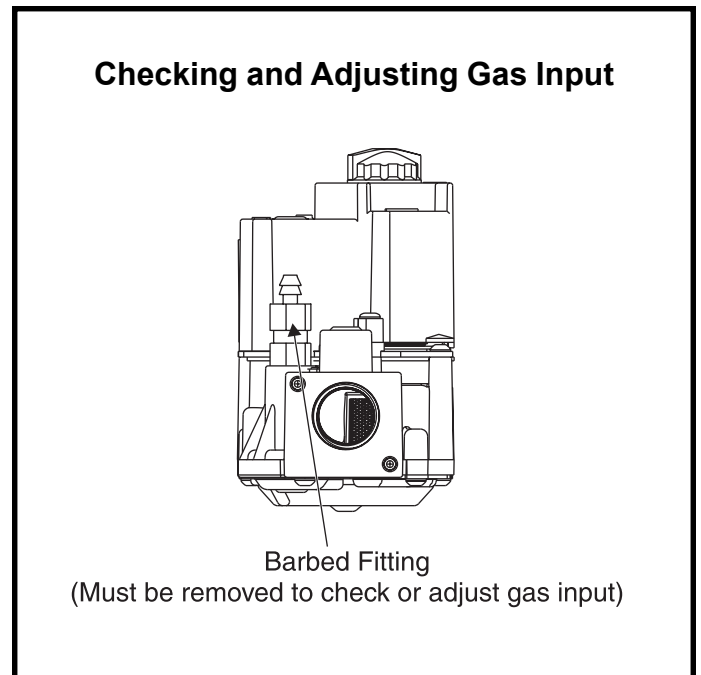
To adjust the regulator, turn the adjusting screw(s) on the regulator clockwise to increase pressure and input; counterclockwise to decrease pressure and input.

Replace the barbed fitting and reconnect the hose after measuring and/or adjusting the regulator.

#### **CAUTION**

The furnace rate must be within +/- 2% of the appliance rating input.

**For Natural Gas:** Check the furnace rate by observing the gas meter, when available, making sure all other gas appliances are turned off. The test hand on the meter



**Figure 20**

should be timed for at least one revolution. Note the number of seconds for one revolution.

$$\text{BTU/HR INPUT} = \frac{\text{Cubic Feet Per Revolution}}{\text{\# Seconds Per Revolution}} \times 3600 \times \text{Heating Value}$$

The heating value of the gas can be obtained from the local utility company.

**For Propane Gas:** The only check for the furnace rate is to properly adjust the manifold pressure using a manometer and Table 4 on page 22. Typical manifold set point for installations at altitudes from 0 to 4500 feet above sea level is 10.0" W.C.

### Temperature Rise

Check the temperature rise and, if necessary, adjust blower speed to maintain temperature rise within the range shown on the unit rating plate.

### High Altitude

In both the United States and Canada, this furnace is approved for operation at altitudes from 0 to 4500 feet above sea level without any required modifications. From 4500 to 7500 feet, the gas manifold pressure needs to be adjusted according to the information shown in Table 4 on page 22. To adjust the manifold pressure, refer to previous section **Checking and Adjusting Gas Input**. For installations above 7500 feet, call Technical Service at 1-800-448-5872 ext. 2610 for assistance.

## Manifold Pressure vs. Altitude

Altitude (ft.)	Natural Gas		Propane (LP)		Input Factor
	Heating Value* (BTU/ft <sup>3</sup> )	Manifold Pressure (in. W.C.)	Heating Value* (BTU/ft <sup>3</sup> )	Manifold Pressure (in. W.C.)	
2000	948	3.50	2278	10.00	0.9666
3000	914	3.50	2196	10.00	0.9499
4000	881	3.50	2116	10.00	0.9332
4500	865	3.50	2077	10.00	0.9249
5000	849	3.29	2039	9.41	0.8900
5500	833	3.27	2000	9.35	0.8790
6000	818	3.25	1964	9.29	0.8680
6500	802	3.23	1927	9.24	0.8570
7000	787	3.21	1891	9.18	0.8460
7500	771	3.19	1853	9.12	0.8350

\* Consult local utility for actual heating value.

Furnace Input = Input Factor x Nameplate Input

Above 7500 feet, call Technical Services at 1-800-448-5872 ext. 2610.

**Table 4**

## MAINTENANCE

### **⚠ WARNING**

#### **ELECTRICAL SHOCK, FIRE, OR EXPLOSION HAZARD**

Failure to follow the safety warnings exactly could result in dangerous operation, serious injury, death, or property damage.

Improper servicing could result in dangerous operation, serious injury, death, or property damage.

- Before servicing, disconnect all electrical power to furnace.
- When servicing controls, label all wires prior to disconnecting. Reconnect wires correctly.
- Verify proper operation after servicing.

It is recommended that this furnace be inspected by a qualified service technician at the beginning of each heating season.

### **Filters**

Filters should be checked at least every 6 weeks. Disposable filters should be replaced when dirty, and cleanable filters should be cleaned regularly. It is important to keep the air filters clean, as dirty filters can restrict airflow and the blower and induced draft motors depend upon sufficient air flowing across and through them to keep from overheating.

### **Lubrication**

The blower motor and induced draft motor are pre-lubricated by the manufacturer and do not require further lubricating attention. However, the motors should be cleaned periodically to prevent the possibility of overheating due to an accumulation of dust and dirt on the windings or on the motor exterior.

### **Condensate Collection and Disposal System**

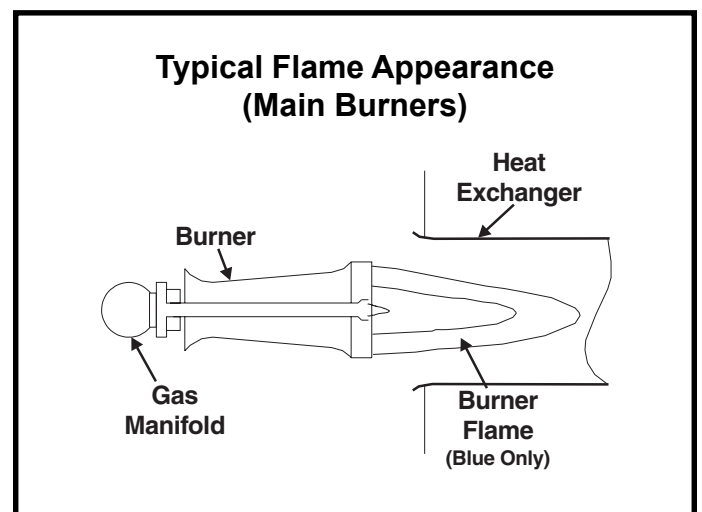
Check the condensate drain line periodically for blockage. Visual inspection of condensate flow can be done easily while the furnace is in operation. Use a flashlight to illuminate the discharge end of the condensate drain that is placed in the sewer opening. If the condensate drain line becomes blocked or plugged, the furnace will not operate properly.

## **Main Burners**

Light the burners and allow to operate for a few minutes to establish normal burning conditions. Observe the main burner flames. Compare this observation to Figure 21 to determine if proper flame adjustment is present. Flame should be predominantly blue in color and strong in appearance. Check that all burners are lit, and that the flame does not impinge on the sides of the heat exchanger.

Distorted flame or yellow tipping of the natural gas main burner flame, or long yellow tips on propane, may be caused by lint accumulation or dirt inside the burner or burner ports, at the air inlet between the burner and manifold pipe, or obstructions over the main burner orifice.

Use a soft brush or vacuum to clean the affected areas.



**Figure 21**

## REPAIR PARTS

The following repair parts are available from the local distributor. When ordering parts, include the complete furnace model number and serial number which are printed on the rating plate located on the furnace.

### Control Group

Transformer  
High limit control  
Auxiliary limit (if used)  
Gas valve  
Ignition/blower control board  
Flame sensor  
Pressure switch  
Blower door interlock switch  
Combustion blower assembly  
Flame rollout protector switch  
Hot surface igniter

### Heat Exchanger Group

Heat exchanger – primary  
Heat exchanger – secondary  
Condensate drain pan

### Blower Group

Blower housing assembly  
Blower wheel  
Blower motor  
Blower motor mount  
Blower motor capacitor

### Burner Group

Gas manifold  
Main burner orifices  
Main burners

### Accessories

ALPKT572 Natural Gas to Propane Conversion Kit  
(G1D91BU and CG90UB)  
ALPKT574 Natural Gas to Propane Conversion Kit  
(G1D93BU, G1D93BC, and CG90CB)  
AFILTHA7 Single Side Filter Frame Kit  
AFILT524 Side Return Filter Kit (upflow models)  
AFILT529 Bottom Return Filter Kit  
AFILT525 Return Filter Kit (counterflow models)  
ANGKT557 Propane to Natural Gas Conversion Kit  
(G1D91BU and CG90UB)  
ANGKT556 Propane to Natural Gas Conversion Kit  
(G1D93BU, G1D93BC, and CG90CB)  
ATWIN579 Twinning Kit  
ACVK2 Concentric Vent Kit  
ABASE512 Combustible Floor Base (17.5" cabinets)  
ABASE568 Combustible Floor Base (21.0" cabinets)  
ABASE569 Combustible Floor Base (24.5" cabinets)



# CONTROL SYSTEM DIAGNOSTICS

## Troubleshooting

The following visual checks should be made before troubleshooting:

1. Check to see that the power to the furnace and the blower control board is on.
2. The manual shutoff valves in the gas line to the furnace must be open.
3. Make sure all wiring connections are secure.
4. Review the **Sequence of Operation** (see page 20).

Start the system by setting the thermostat above the room temperature. Observe the system's response. Then use the information provided in this section to check the system's operation.

The furnace has a built-in, self-diagnostic capability. If a system problem occurs, a fault code is shown by an LED on the control board. The control continuously monitors its own operation and the operation of the system. If a failure occurs, the LED will indicate the failure code. The flash codes are presented in Table 5.

### ***Fault Code History Button***

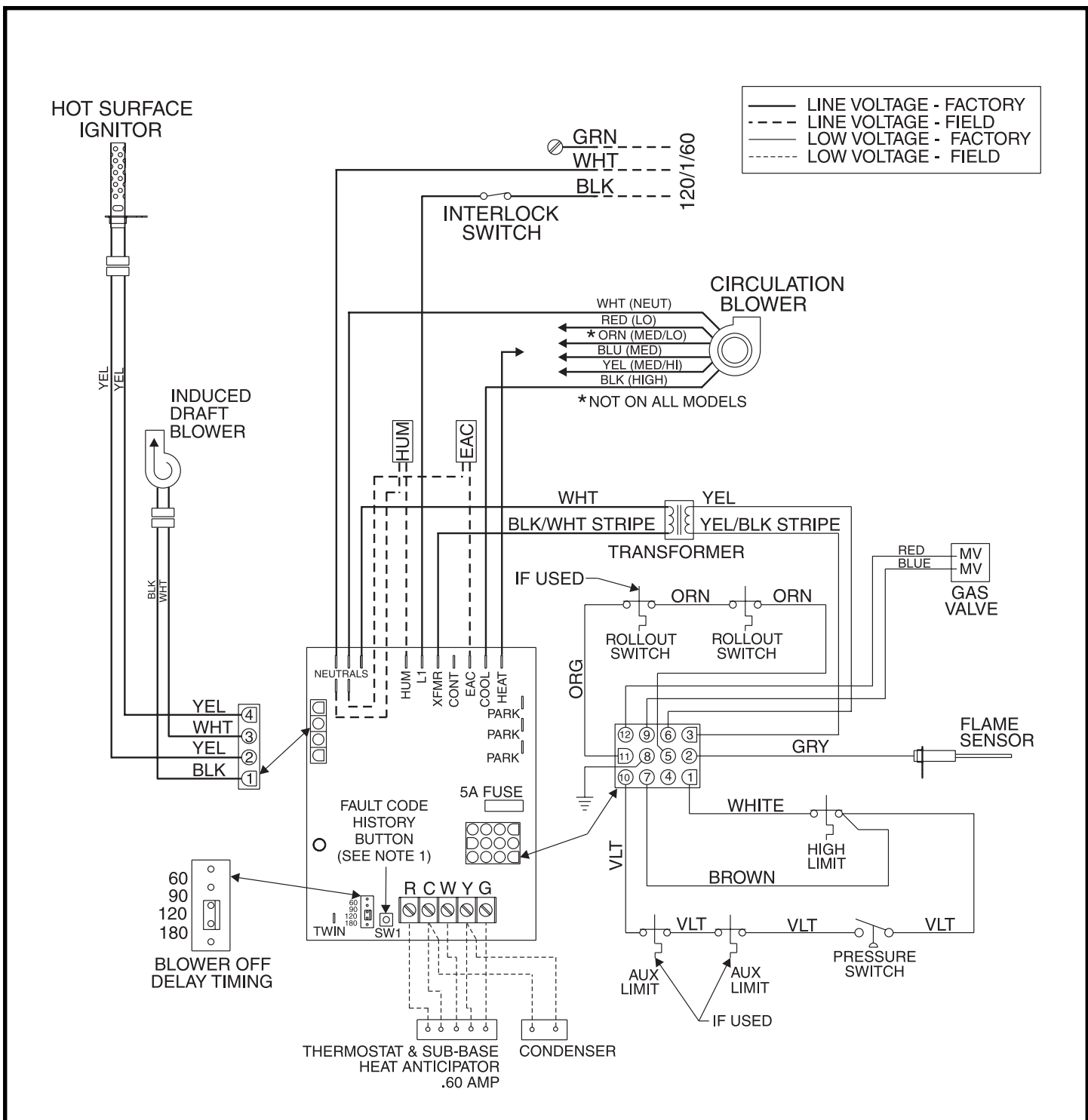
The control stores the last five fault codes in memory. A pushbutton switch is located on the control (see Figure 22 on page 26). When the pushbutton switch is pressed and released, the control flashes the stored fault codes. The most recent fault code is flashed first; the oldest fault code is flashed last.

To clear the fault code history, press and hold the pushbutton switch in for more than 5 seconds before releasing.

## Failure Codes

LED Status	Fault Description
LED Off	No power to control or control hardware fault detected
LED On	Normal operation
1 Flash	Flame present with gas valve off
2 Flashes	Pressure switch closed with inducer off
3 Flashes	Pressure switch open with inducer on
4 Flashes	High limit switch open
5 Flashes	Rollout switch open
6 Flashes	Pressure switch cycle lockout
7 Flashes	Lockout due to no ignition
8 Flashes	Lockout due to too many flame dropouts
9 Flashes	Incorrect line voltage phasing

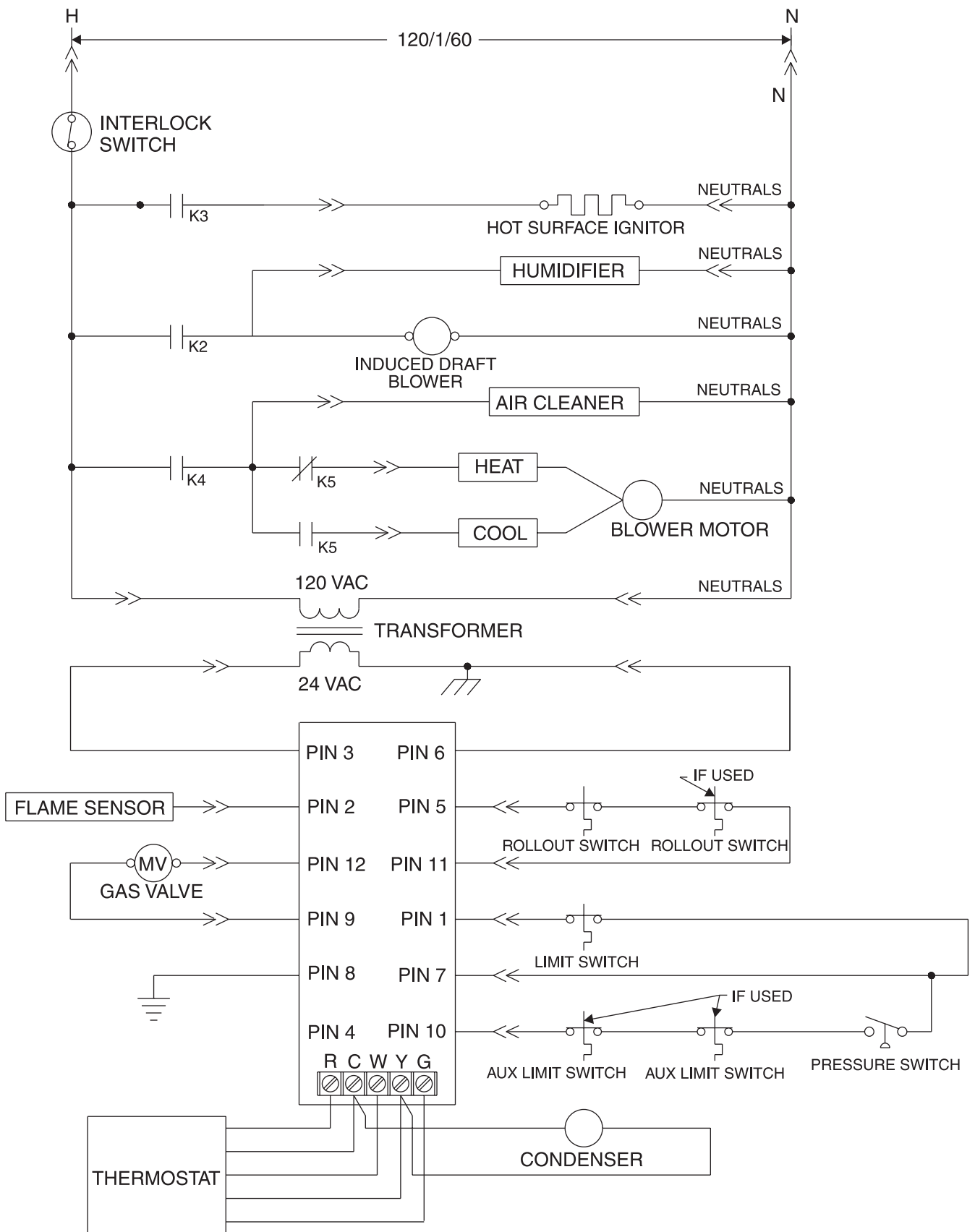
**Table 5**



1. PRESS AND RELEASE FAULT CODE HISTORY BUTTON TO DISPLAY FAULT CODES. TO ERASE CODES, PRESS AND HOLD BUTTON IN FOR MORE THAN 5 SECONDS.
2. IF ANY OF THE ORIGINAL WIRE AS SUPPLIED WITH THE FURNACE MUST BE REPLACED, IT MUST BE REPLACED WITH WIRING MATERIAL HAVING A TEMP. RATING OF AT LEAST 90°C.

CHECK CODES FOR PROPER WIRING AND CIRCUIT PROTECTION BEFORE INSTALLATION.

**Connection Diagram  
P/N 45198-005**



**Schematic Diagram  
P/N 45198-005**