

# SPLIT SYSTEM HEAT PUMP INSTALLATION / START-UP INSTRUCTIONS /HOMEOWNERS INFORMATION MANUAL

These instructions must be read and understood completely before attempting installation.

Issue 0541

## TABLE OF CONTENTS

Safety Precautions .....	2	Electrical Connections .....	5
Unit Location & Installation .....	2	Control Wiring .....	5
Rooftop Installation & Recommendations .....	3	Start-Up Procedure .....	6
Indoor Coil Piston Selection .....	3	Adjusting charge .....	6
Refrigeration Line Sets .....	3	Defrost System .....	7
Installation of Line Sets .....	4	Wiring Diagram .....	9
Leak Check .....	4	Homeowner's Information .....	10
Evacuating & Charging .....	4	Warranty .....	12
Opening Service Valve .....	5		

These units are designed for use in residential and commercial type buildings. Heat Pumps are sensitive to indoor units and may only be installed with combinations listed in the Air-Conditioning and Refrigeration Institute (ARI) Directory of Certified Products. Refer to [www.ariprimer.net.org](http://www.ariprimer.net.org).

After uncrating unit, inspect thoroughly for hidden damage. If damage is found, notify the transportation company immediately and file a concealed damage claim.

### **WARNING**

Installation or repairs made by unqualified persons can result in hazards to you and others. Installation MUST conform with local building codes or, in the absence of local codes, with the National Electrical Code NFPA 70/ANSI C1-1993 or current edition and Canadian Electrical Code Part 1 CSA C22.1.

### **CAUTION**

Improper installation, adjustment, alteration, service or maintenance will void the warranty. The qualified installer or agency must use factory-authorized kits or accessories when modifying this products. Refer to the individual instructions packaged with the kits or accessories when installing.

### **NOTE**

These instructions are intended as a general guide and do not supersede national, state or local codes in any way.  
***These instructions must be left with the property owner.***

### NOTE TO INSTALLING DEALER

These instructions and warranty are to be given to the owner or prominently displayed near the indoor air handler unit.

### **⚠ WARNING**

This product and/or the indoor unit it is matched with may contain fiberglass wool.

Disturbing the insulation during installation, maintenance, or repair will expose you to fiberglass wool dust. Breathing this may cause lung cancer. (Fiberglass wool is known to the State of California to cause cancer.)

Fiberglass wool may also cause respiratory, skin, and eye irritation.

To reduce exposure to this substance or for further information, consult material safety data sheets available from your distributor.

### **⚠ WARNING**

Before installing, modifying, or servicing system, main electrical disconnect switch must be in the OFF position. There may be more than 1 disconnect switch. Lock out and tag switch with a suitable warning label. Electrical shock can cause personal injury or death.

## Safety Precautions

Follow all safety codes. Wear safety glasses and work gloves. Use quenching cloth for brazing operations. Have fire extinguisher available. Read these instructions thoroughly and follow all warning or cautions attached to the unit.

1. Always wear proper personal protection equipment.
2. Always disconnect electrical power before removing panel or servicing equipment.
3. Keep hands and clothing away from moving parts.
4. Handle refrigerant with caution, refer to proper MSDS from refrigerant supplier.
5. Use care when lifting, avoid contact with sharp edges.

## UNIT LOCATION & INSTALLATION

**NOTE:** In some cases noise in the living area has been traced to gas pulsations from improper installation of equipment.

1. Locate unit away from windows, patios, decks, etc. where unit operation sounds may disturb customer.
2. Ensure that vapor and liquid tube diameters are appropriate to capacity of unit.
3. Run refrigerant tubes as directly as possible by avoiding unnecessary turns and bends.
4. Leave some slack between structure and unit to absorb vibration.
5. When passing refrigerant tubes through the wall, seal opening with RTV or other silicon-based caulk.
6. Avoid direct tubing contact with water pipes, duct work, floor joists, wall studs, floors, walls, and any structure.
7. Do not suspend refrigerant tubing from joists and studs with a rigid wire or strap which comes in direct contact with tubing.
8. Ensure that tubing insulation is pliable and completely surrounds vapor tube.

When outdoor unit is connected to factory-approved indoor unit, outdoor unit contains system refrigerant charge for operation with indoor unit of the same size when connected by 15 ft. of field-supplied tubing. For proper unit operation, check refrigerant charge using charging information located on control box cover.

**IMPORTANT:** Maximum liquid-line size is 3/8 in. O.D. for all residential applications including long lines.

### **Outdoor Section**

Zoning ordinances may govern the minimum distance the condensing unit can be installed from the property line.

### **Install on a Solid, Level Mounting Pad**

The outdoor section is to be installed on a solid foundation. This foundation should extend a minimum of 2" (inches) beyond the sides of the outdoor section. To reduce the possibility of noise transmission, the foundation slab should NOT be in contact with or be an integral part of the building foundation.

**Elevate Unit**

**CAUTION**

Accumulation of water and ice in base pan may cause equipment damage.

Elevate unit per local climate and code requirements to provide clearance above estimated snowfall level and ensure adequate drainage of unit. Use snow stand in areas where prolonged freezing temperatures are encountered.

If conditions or local codes require the unit be attached to pad or mounting frame, tie down bolts should be used and fastened through knockouts provided in unit base pan.

**Roof Top Installations**

Mount on level platform or frame 6 inches above roof surface. Place unit above a load-bearing wall and isolate unit and tubing set from structure. Arrange supporting members to adequately support unit and minimize transmission of vibration to building. Ensure roof structure and anchoring method is adequate for location. Consult local codes governing rooftop applications.

Roof mounted units exposed to winds above 5 mph may require wind baffles to achieve adequate defrost. A sheet metal baffle should be spaced 6-1/2" from the fall of the coil. The height should cover the face of the coil and the length should be 6" from the access panel.

**NOTE:** Unit must be level to within  $\pm 2^\circ$  ( $\pm 3/8$  in./ft) per compressor manufacturer specifications.

**Clearance Requirements**

When installing, allow sufficient space for airflow clearance, wiring, refrigerant piping, and service. For proper airflow, quiet operation and maximum efficiency. Position so water, snow, or ice from roof or eaves cannot fall directly on unit.

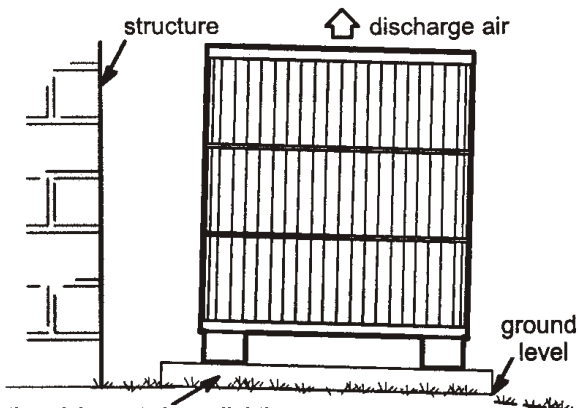

F0000436

**DO LOCATE THE UNIT:**

- With proper clearances on sides and top of unit
- On a solid, level foundation or pad
- To minimize refrigerant line lengths
- With elevation efficient for freezing condensate

**DO NOT LOCATE THE UNIT:**

- On brick, concrete blocks or unstable surfaces
- Near clothes dryer exhaust vents
- Near sleeping area or near windows
- Under eaves where water, snow or ice can fall directly on the unit

**Operating Ambients**

The minimum outdoor operating ambient in cooling mode is 55°F, and the maximum outdoor operating ambient in cooling mode is 125°F. The maximum outdoor operating ambient in heating mode is 66°F.

**Indoor Coil Piston Selection**

The outdoor heat pump section must be matched to a factory approved indoor section. It is mandatory that the installer ensure that the correct piston is installed in the indoor section. If necessary remove the existing piston and replace it with the correct piston. See indoor unit instructions for details of changing the piston. Contact your distributor for accessory piston kits.

**Indoor (Cooling) Piston Size**

13 SEER Heat Pump Indoor Piston Sizes	
Unit Size	Piston Size
18	.055
24	.063
30	.068
36	.076
42	.076
48	.082
60	TXV ONLY

The evaporator coil may use an expansion valve (TXV) in place of piston.

**Refrigeration Line Sets**

Fully annealed refrigeration lines must be used when installing the system. Use only refrigerant grade copper pipe. Split systems may be installed with up to 50 feet of line set (no more than 20 feet vertical) without special consideration.

## Recommended Liquid & Vapor Tube Diameters (In.)

Unit Size	LIQUID		VAPOR	
	Connection Dia.	Tube Dia.	Connection Dia.	Tube Dia.
018	3/8"	3/8"	3/4	3/4
024	3/8"	3/8"	3/4	3/4
030	3/8"	3/8"	3/4	3/4
036	3/8"	3/8"	3/4	3/4
042	3/8"	3/8"	7/8	7/8
048	3/8"	3/8"	7/8	7/8
060	3/8"	3/8"	7/8	*1-1/8

\*FIELD SUPPLIED 7/8 X 1-1/8 CONNECTOR REQUIRED ON BOTH ENDS OF VAPOR TUBING.

It is important that no tubing be cut or seals broken until you are ready to actually make connections to the evaporator and to the condenser section. DO NOT remove rubber plugs or copper caps from the tube ends until ready to make connections at evaporator and condenser. Under no circumstances leave the lines open to the atmosphere for any period of time, if so unit requires additional evacuation to remove moisture.

Be *extra careful* with sharp bends. Tubing can "kink" very easily, and if this occurs, the entire tube length will have to be replaced. *Extra care* at this time will eliminate future service problems.

It is recommended that vertical suction risers not be up-sized. Proper oil return to the compressor should be maintained with suction gas velocity.

### Installation Of Line Sets

DO NOT fasten liquid or suction lines in direct contact with the floor or ceiling joist. Use an insulated or suspension type of hanger. Keep both lines separate, and always insulate the suction line. Long liquid line runs (30 feet or more) in an attic will require insulation. Route refrigeration line sets to minimize length.

DO NOT let refrigerant lines come in direct contact with foundation. When running refrigerant lines through the foundation or wall, openings should allow for a sound and vibration absorbing material to be placed or installed between tubing and foundation. Any gap between foundation or wall and refrigerant lines should be filled with a vibration damping material.

### **CAUTION**

If ANY refrigerant tubing is buried, provide a 6 inch vertical rise at service valve. Refrigerant tubing lengths up to 36 inches may be buried without further special consideration. For lengths above 36 inches, consult your local distributor.

Before making braze connections, be sure all joints are clean. Before heat is applied for brazing, dry nitrogen should be flowing through the tubing to prevent oxidation and scale formation on the inside of the tubing.

The following is the recommended method for making braze connections at the refrigerant line connections:

1. Deburr and clean refrigerant tube end with emery cloth or steel brush.
2. Insert tubing into swage fitting connection.
3. Wrap wet rags over valves to protect from heat.
4. Allow dry nitrogen to flow through refrigerant lines.
5. Braze joint, using a suitable brazing alloy for copper to copper joints.
6. Quench the joint and tubing with water using a wet rag. Leave rag on fitting body and re-wet with water to help cool area.

### Leak Check

Refrigeration lines and indoor coil must be checked for leaks after brazing and before evacuation. The recommended procedure is to apply a trace amount of vapor refrigerant (approximately two ounces or 3 psig) into the line set and indoor coil, then pressurize with 150 psig of dry nitrogen. Use a refrigerant leak detector to check all joints. The system may also be checked for leaks using a halide torch or pressure and soapy solution. After completion of leak check, relieve all pressure from system before evacuation.

### Evacuating And Charging Instructions

**NOTE: Intentional release of CFC or HCFC refrigerant to the atmosphere violates Federal Law. It may also violate State and Local Codes. Check all Federal, State and Local Codes before proceeding.**

These outdoor units are pre-charged at the factory with adequate refrigerant to handle **15 feet** of refrigerant tubing.

**NOTE:** DO NOT use any portion of the charge for purging or leak testing. It is mandatory that a thorough evacuation of the refrigeration lines and indoor coil be performed.

The liquid line and suction line service valves have been closed after final testing at the factory. *DO NOT disturb these valves until the lines have been leak checked and evacuated or the charge in the unit may be lost.*

1. Connect the vacuum pump to the center hose of the manifold gauge set, the low-pressure manifold gauge to the vapor service valve and the high pressure manifold gauge to the liquid service valve.

**NOTE:** Unnecessary switching of hoses can be avoided and complete evacuation of all lines can be achieved by also connecting a branch hose from the manifold gauge center port to a cylinder of R-22. Provide a separate shut-off valve to vacuum pump to avoid contaminating vacuum pump oil with refrigerant.

2. The valves should be kept in the "front seated" (closed) position. This will allow evacuation of the refrigeration lines and the indoor coil, without disturbing the factory charge in the outdoor unit.
3. Follow the vacuum pump manufacturer's instructions. Allow the pump to operate until the system has been evacuated down to 300 microns. Allow the pump to continue running for an additional 15 minutes. Turn OFF the pump and leave the connections secured to the two (2) service valves. After 5 minutes, if the system fails to hold 500 microns or less, check all connections for tight fit and repeat the evacuation procedure.
4. Isolate the vacuum pump from the system by closing the shutoff valves on the gauge-set. Disconnect the vacuum pump.

### **Opening Service Valves**

After evacuation of the connecting lines, remove the service valve cap and fully insert the hex wrench into the stem. A back-up wrench is required on the valve body to open the valve stem. Back-out counterclockwise until the valve stem just touches the coined edge.

Wrench sizes:

- 3/8 service valve: 3/16" Hex wrench
- 3/4 service valve: 5/16" Hex wrench
- 7/8 service valve: 5/16" Hex wrench

Replace service valve cap and torque to 8-11 ft-lb on 3/8" valves; 12-15 ft-lb on 3/4" valves; 15-20 ft-lb on 7/8" valves. Use backup wrench on valve body when torquing valve cap.

### **Install Electrical Accessories**

Refer to the instructions packaged with the accessories.

### **Electrical Connections**

#### **⚠ WARNING**

#### ***ELECTRICAL SHOCK HAZARD!***

Turn OFF electric power before connecting unit, performing any maintenance or removing panels or doors. More than one disconnect may be required to turn off all power.

**FAILURE TO DO SO COULD RESULT IN BODILY INJURY OR DEATH.**

Be sure to check all local codes to determine that the unit is installed accordance with local requirements. Consult the National Electric Code for wire size requirements. Use 60° C wire or higher. Always provide ground connections to the outdoor unit. Power supply must agree with rating on unit nameplate.

Provide line voltage power supply to unit from a properly sized disconnect switch. Route power and ground wires from disconnect switch to unit. Line voltage connections are made at the line side of the contactor in the control box of the outdoor unit. Follow the appropriate wiring diagram attached to inside of the access panel.

Proper circuit protection recommendations are indicated on Unit Rating Plate. Time delay fuses are required to prevent blowing due to starting current (the current in rush when equipment starts is referred to as the Locked Rotor Amps or (LRA). A fuse of this kind properly sized will give maximum equipment protection.

Use copper wire only between disconnect switch and unit.

Remove access panel to gain access to unit wiring. Extend wires from disconnect through power wiring hole provided and into unit control box. Flexible conduit is required for the swing out control box feature.

#### **⚠ WARNING**

The unit cabinet must have an uninterrupted or unbroken ground to minimize personal injury if an electrical fault should occur. The ground may consist of electrical wire or metal conduit when installed in accordance with existing electrical codes. Failure to follow this warning can result in an electric shock, fire, or death.

Connect ground wire to ground connection in control box for safety. Connect power wiring to contactor.

High voltage power connections to 3-phase models is made to "Pig Tail" leads with field supplied splice connectors.

### **Control Wiring**

The control voltage is 24 Vac. NEC Class I insulated 18 AWG is required for control wiring. For lengths longer than 150 feet, contact your local distributor for technical service.

Ensure the room thermostat is properly installed per instructions shipped with room thermostat. Generally the thermostat should not be exposed to sunlight, drafts or vibration and should not be mounted on exterior walls.

Low voltage control wire connections should be made to the screw connection terminal board mounted on the defrost control as shown. All low voltage control wiring must be separated from incoming power leads.

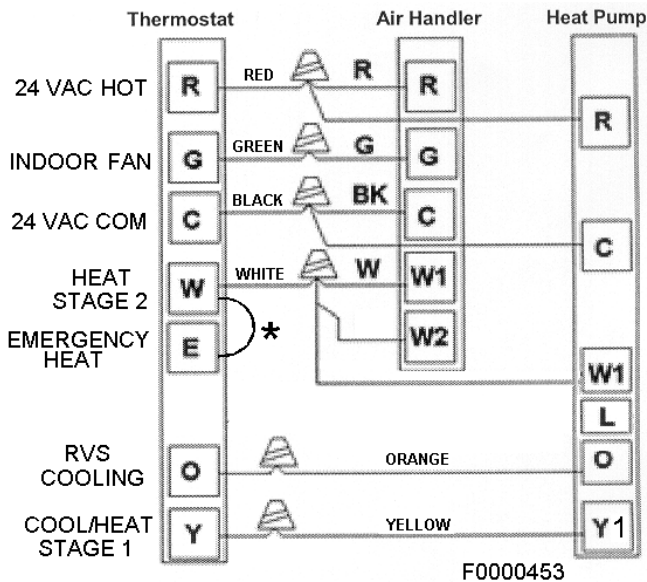

### Adjusting Charge

Factory charge is shown on the rating label located on the access panel.

**All split system heat pumps are factory charged for 15 feet of connecting line set and matched indoor fan coil.** Nameplate refrigerant charge should initially be adjusted for line set lengths other than 15 feet. For line sets shorter than 15 feet in length, remove charge. For line sets longer than 15 feet, add charge. Oil charge is sufficient for all line lengths.

Refrigeration Charge Adjustment	
Liquid Line Diameter	Oz. Per Linear Foot *
3/8"	.6

\* Factory charge for series is for 15' (ft.) line sets and matched fan coil.

Before final adjustment is made to the refrigerant charge, it is imperative proper indoor airflow be established. Airflow will be higher across a dry coil versus a wet coil. Blower charts are calculated with a **dry or wet coil** basis. Recommended airflow is **350-450 CFM per ton** (12,000 Btuh) through a **wet coil**. Refer to indoor unit instructions for methods of determining air flow and blower performance.

Factory charge is shown on unit rating plate. To check charge in cooling mode, refer to Cooling Cycle Procedure. To check charge in heating mode, refer to Heating Check Chart Procedure.

### Cooling Cycle Charge Adjustment Procedure

#### Units with Indoor Pistons

Units installed with indoor pistons require charging with the superheat method.

The following procedure is valid when indoor airflow is within  $\pm 20\%$  of its rated CFM.

1. Operate unit a minimum of 10 minutes before checking charge.
2. Measure suction pressure by attaching a gage to suction valve service port. Do not use compressor suction port. Determine saturation temp from T/P chart.
3. Measure suction temperature by attaching an accurate thermistor type or electronic thermometer to suction line at service valve.
4. Calculate superheat (measured temp. — saturation temp.).
5. Measure outdoor air dry-bulb temperature with thermometer.
6. Measure indoor air (entering indoor coil) wet-bulb temperature with a sling psychrometer.
7. Compare superheat reading at service valve with the chart located on control box cover.
8. If unit has a higher suction line temperature than charted temperature, add refrigerant until charted temperature is reached.

## Heat Pump Application with Electric Heat

### Emergency Heat (heating heat pump)

If selector switch on thermostat is set to the emergency heat position, the heat pump will be locked out of the heating circuit, and all heating will be electric heat (if applicable). A jumper should be placed between W2 and E on the thermostat so that the electric heat control will transfer to the first stage heat on the thermostat. This will allow the indoor blower to cycle on and off with the electric heat when the fan switch is in the AUTO position.

\* Add Jumper on Subbase (Optional)

### Start-Up Procedure

1. Check to ensure:
  - Service valve and gage port caps are installed and tightened.
  - Voltage supply at unit agrees with nameplate rating.
  - Field wiring connections are tight and factory wiring has not been disturbed and are tight.
  - Indoor fan motor is on correct speed tap.
2. Set thermostat selector switch to OFF and fan control switch to "Auto" if so equipped.
3. Close electrical disconnects to energize system.
4. Set room thermostat at desired temperature. Be sure set point is below indoor ambient temperature.
5. Set the system switch of the thermostat on COOL (or HEAT if applicable) and fan switch for continuous operation (ON) or AUTO, as desired. There will be a 5 minute short cycle compressor delay on startup. Operate unit for 15-20 minutes, then check the system refrigerant charge.
6. Adjust refrigerant charge per "Adjusting Charge" section.



9. If unit has a lower suction line temperature than charted temperature, reclaim refrigerant until charted temperature is reached.
10. Remove charge if superheat is low and add charge if superheat is high.

### **Units with Indoor TXV**

Units installed with cooling mode TXV require charging with the subcooling method.

1. Operate unit a minimum of 10 minutes before checking charge.
2. Measure liquid service valve pressure by attaching an accurate gage to service port. Determine saturation temp. from T/P chart.
3. Measure liquid line temperature by attaching an accurate thermistor type or electronic thermometer to liquid line near outdoor coil.
4. Calculate subcooling (saturation temp.— measured temp.).
5. Find the point where required subcooling temperature intersects measured liquid service valve pressure.
6. Add refrigerant if subcooling is lower than table below. Recover refrigerant if subcooling is high. ( $\pm 3^\circ \text{F}$ .)

<b>Model</b>	<b>Required Subcooling (<math>\pm 3^\circ \text{F}</math>)</b>
18	14
24	9
30	13
36	9
42	11
48	8
60	12

### **Heating Check Chart Procedure**

To check system operation during heating cycle, refer to the Heating Check Chart located on back of control box cover. This chart indicates whether a correct relationship exists between system operating pressure and air temperature entering indoor and outdoor units. If pressure and temperature do not match on chart, system refrigerant charge may not be correct. **Do not use chart to adjust refrigerant charge.**

Charge must be rechecked again during the cooling season.

## **SYSTEM OPERATION**

The outdoor unit and indoor blower cycle on demand from the room thermostat. When the thermostat blower switch is in the ON position, the indoor blower operates continuously.

### **Filter Drier**

The outdoor unit is equipped with a bi-flow filter drier. If replacement is necessary, order new dryer according to the service parts manual.

### **Emergency Heat Function (Room Thermostat)**

An emergency heat function is designed into some room thermostats. This feature is applicable when isolation of outdoor unit is required or when auxiliary electric heat is staged by outdoor thermostats. When the room thermostat is placed in the emergency heat position, the outdoor unit control circuit is isolated from power and field-provided relays bypass the outdoor thermostats. An amber indicating light simultaneously comes on to remind the homeowner that he is operating in the emergency heat mode.

Emergency heat is usually used during an outdoor unit shutdown, but it should also be used following a power outage. If power has been off for over an hour and the outdoor temperature is below  $50^\circ \text{F}$  ( $10^\circ \text{C}$ ). System should be left in the emergency heat mode at least six hours to allow the crankcase heater sufficient time to prevent compressor slugging. This applies only to systems with crank case heaters.

### **Defrost System**

The 2HP13 defrost system includes two (2) components: a defrost thermostat and a defrost control.

#### **Defrost Thermostat**

The defrost thermostat is located on the liquid line between the check/expansion valve and the distributor. When defrost thermostat senses  $29^\circ \text{F}$  or cooler, the thermostat contacts close and send a signal to the defrost control board to start the defrost timing. It also terminates defrost when the liquid line warms up to  $60^\circ \text{F}$ .

#### **Defrost Control**

The defrost control board includes the combined functions of a time/temperature defrost control, defrost relay, diagnostic LEDs and terminal strip for field wiring connections.

The control provides automatic switching from normal heating operation to defrost mode and back. During compressor cycle, the control accumulates compressor run times at 30-, 60-, or 90-minute field-adjustable intervals. If the defrost thermostat is closed when the selected compressor run time interval ends (call for

defrost), the defrost relay is energized and defrost begins. The factory setting is 90 minutes.

### Outdoor Unit Defrost Control Board

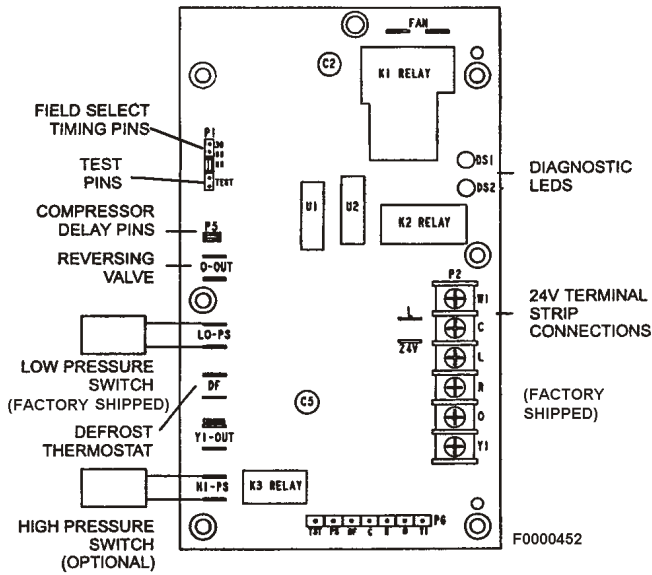

#### Defrost Control Timing Pins

Each timing pin selection provides a different accumulated compressor run time period for one defrost cycle. This time period must occur before a defrost cycle is initiated. The defrost interval can be adjusted to 30 (T1), 60 (T2), or 90 (T3) minutes. The defrost timing jumper is factory-installed to provide a 90-minute defrost interval. If the timing selector jumper is not in place the control defaults to a 90-minute defrost interval. The maximum defrost period is 14 minutes and cannot be adjusted.

A TEST option is provided for troubleshooting. **The TEST mode may be started any time the unit is in the heating mode and the defrost thermostat is closed or jumpered.** If the jumper is in the TEST position at power-up, the control will ignore the test pins. When the jumper is placed across the TEST pins for 2 seconds, the control will enter the defrost mode. If the jumper is removed before an additional 5 second period has elapsed ( 7 seconds total), the unit will remain in defrost mode until the defrost thermostat opens or 14 minutes have passed. If the jumper is not removed until after the additional 5 second period has elapsed, the defrost will terminate and the test option will not function again until the jumper is removed and re-applied.

#### Compressor Delay

The defrost board has a field-selectable function to reduce occasional sounds that may occur while the unit is cycling in and out of the defrost mode. The compressor will be cycled "off" for 30 seconds going in and out of the defrost mode when the compressor delay jumper is removed.

**NOTE:** The 30 second "off" cycle is not functional when jumpering the TEST pins.

#### Time Delay

The timed-off delay is 5 minutes long. The delay help to protect the compressor from short-cycling in case the power to the unit is interrupted or a pressure switch opens. The delay is bypassed by placing the timer select jumper across the TEST pins for 0.5 seconds.

#### Pressure Switch Circuit

The defrost control incorporates 2 pressure switch circuits. The optional high pressure switch connects to the boards HI PS terminals. The low pressure switch is factory installed.

During a single demand cycle, the defrost control will lock out the unit after the fifth time that the circuit is interrupted by any pressure switch wired to the control board. In addition, the diagnostic LEDs will indicate a locked-out pressure switch after the fifth occurrence of an open pressure switch. The unit will remain locked out until power to the board is interrupted, then re-established or until the jumper is applied to the TEST pins for 0.5 seconds.

**NOTE:** The defrost control board ignores input from the low-pressure switch terminals as follows:

- During the TEST mode,
- During the defrost cycle,
- During the 90 second start-up period,
- and for the first 90 seconds each time the reversing valve switches heat/cool modes. **If the TEST pins are jumpered and the 5 minute delay is being bypassed, the LO PS terminal signal is not ignored during the 90 second start-up period.**

#### Diagnostic LEDs

The defrost board uses 2 LEDs for diagnostics. The LEDs flash a specific sequence according to the condition.

**Defrost Control board Diagnostic LED**

Mode	Green LED (DS2)	Red LED (DS1)
No power to control	OFF	OFF
Normal operation/ power to control	Simultaneous Slow FLASH	
Anti-short cycle lockout	Alternating Slow FLASH	
Low pressure switch fault (Optional)	OFF	Slow FLASH
Low pressure switch lockout (Optional)	OFF	ON
High pressure switch fault (Optional)	Slow FLASH	OFF
High pressure Switch lockout (Optional)	ON	OFF



# H/P WIRING DIAGRAM

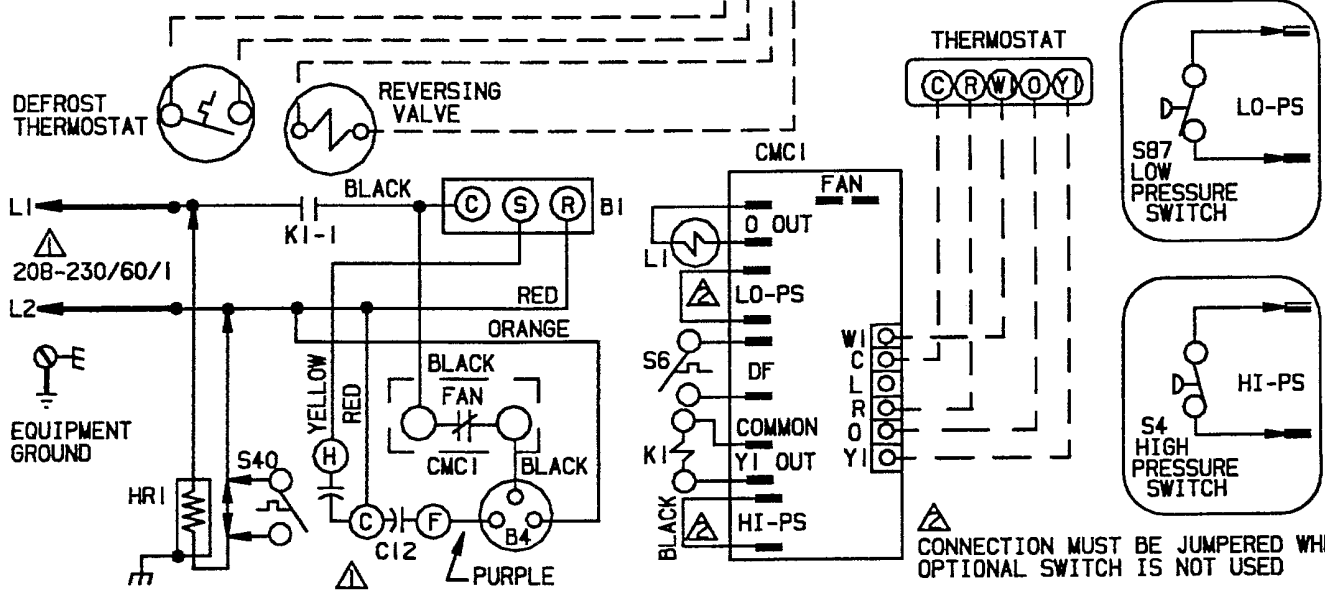
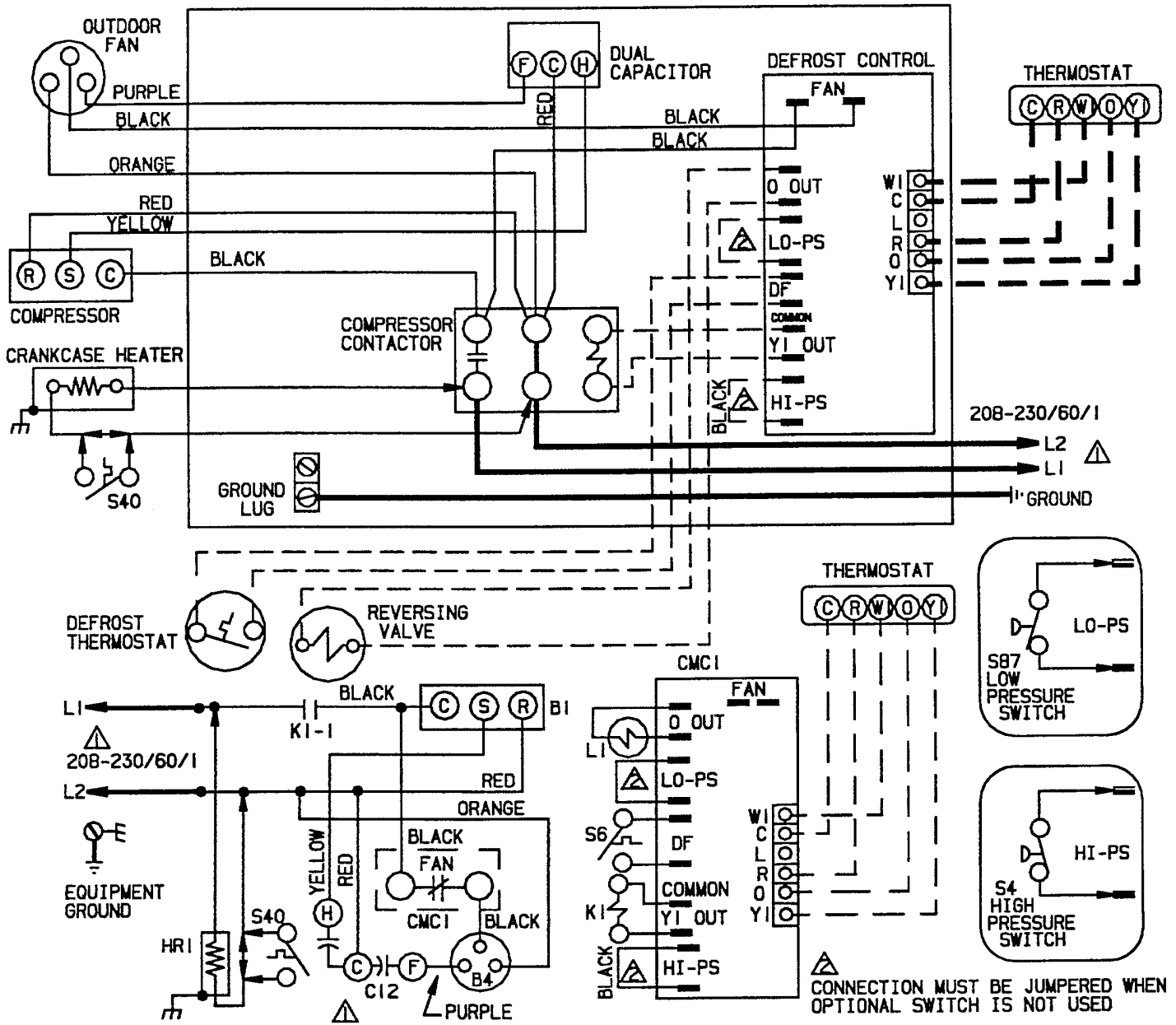

NOTE-  
FOR USE WITH COPPER CONDUCTORS ONLY. REFER TO UNIT RATING PLATE FOR MINIMUM CIRCUIT AMPACITY AND MAXIMUM OVER-CURRENT PROTECTION SIZE.

WARNING-  
ELECTRIC SHOCK HAZARD, CAN CAUSE INJURY OR DEATH. UNIT MUST BE GROUNDED IN ACCORDANCE WITH NATIONAL AND LOCAL CODES.

← DENOTES OPTIONAL COMPONENTS  
 ——— LINE VOLTAGE FIELD INSTALLED  
 - - - CLASS II VOLTAGE FIELD INSTALLED

KEY	DESCRIPTION
B1	COMPRESSOR
B4	MOTOR-OUTDOOR FAN
C12	CAPACITOR- DUAL
CMC1	CONTROL-DEFROST
HR1	HEATER-COMPRESSOR
K1-1	CONTACTOR-COMPRESSOR
L1	VALVE-REVERSING
S4	SWITCH-HIGH PRESSURE
S6	SWITCH-DEFROST
S40	THERMOSTAT-CRANKCASE
S87	SWITCH-LOW PRESSURE

F000451

Supersedes Form No.	
07/05	
New Form No.	
BAR CODE	100458-03, REV C

©2005

Litho U.S.A.

# Homeowner's Information

## **⚠ WARNING**

### *ELECTRICAL SHOCK HAZARD!*

Turn OFF electric power to unit before performing any maintenance or removing panels or doors.

FAILURE TO DO SO COULD RESULT IN BODILY INJURY OR DEATH.

dealer for specific information regarding the model of thermostat installed.

### **Temperature Setting Levers**

Most heat pump thermostats have 2 temperature selector levers: one for heating and one for cooling. Set the levers or dials to the desired temperature set points for both heating and cooling. Avoid frequent temperature adjustment; turning the unit off and back on before pressures equalize puts stress on the unit compressor.

On heat pump systems, increasing your thermostat setting by more than 2 degrees may cause supplemental heaters to turn on, reducing potential energy savings.

### **Fan Switch**

In AUTO or INT (intermittent) mode, the blower operates only when the thermostat calls for heating or cooling. This mode is generally preferred when humidity control is a priority. The ON or CONT mode provides continuous indoor blower operation, regardless of whether the compressor or auxiliary heat are operating. This mode is required when constant air circulation or filtering is desired.

### **System Switch**

Set the system switch for heating, cooling or auto operation. The auto mode allows the heat pump to automatically switch from heating mode to cooling mode to maintain predetermined comfort settings. Many heat pump thermostats are also equipped with an emergency heat mode which locks out heat pump operation and provides temporary heat supplied by the auxiliary heat.

### **Indicating Light**

Most heat pump thermostats have an amber light which indicates when the heat pump is operating in the emergency heat mode.

### **Temperature Indicator**

The temperature indicator displays the actual room temperature.

### **Fan Control**

For fan control your thermostat may have a Fan Selection Switch that allows you to run the fan continuously or cycle it automatically with the heating or cooling system. Switch the lever to ON for continuous operation and to AUTO for automatic cycling.

For maximum comfort satisfaction and continual air cleaning/filtering, constant fan operation is recommended.

On models without a fan Selection Switch, the fan will cycle with the outdoor unit.

### **Heat Pump Operation**

Your new heat pump has several characteristics that you should be aware of:

- Heat pumps satisfy heating demand by delivering large amounts of *warm* air into the living space. This is quite different from gas-or oil-fired furnaces or an electric furnace which deliver lower volumes of considerably *hotter* air to heat the space.
- Do Not be alarmed if you notice frost on the outdoor coil in the winter months. Frost develops on the outdoor coil during the heating cycle when temperatures are below 45°F. An electronic control activates a defrost cycle lasting 5 to 15 minutes at preset intervals to clear the outdoor coil of the frost.
- During the defrost cycle, you may notice steam rising from the outdoor unit. This is a normal occurrence. The thermostat may engage auxiliary heat during the defrost cycle to satisfy a heating demand; however., the unit will run to normal operation at the conclusion of the defrost cycle.

### **In case of extended power outage...**

If the outdoor temperature is below 50°F and power to your outdoor unit has been interrupted for 6 hours or longer, observe the following when restoring power to your heat pump system.

- Set the room thermostat selector to the "Emergency Heat" setting to obtain temporary heat for a minimum of 6 hours. This will allow system refrigerant pressures and temperatures enough time to return to a stabilized condition.
- In Emergency Heat mode, all heating demand is satisfied by auxiliary heat; heat pump operation is locked out. After a 6 hour "warm-up" period, the thermostat can then be switched to the "Heat" setting and normal heat pump operation may resume.
- Heat pumps (in the cooling mode) remove humidity from your home. Depending on the amount of moisture in the air inside your home, water will trickle from the condensate drain of the cooling coil.

### **Thermostat Operation**

The wall-mounted thermostat controls your air conditioner. The thermostat is available in various configurations from different manufacturers. The information below is typical for most thermostats. Ask your

### **Important System Information**

- Your system should never be operated without a clean air filter properly installed.
- Return air and supply air registers should be free from restrictions or obstructions to allow full flow of air.

### **Regular Maintenance Requirements**

Your system should be regularly inspected by a qualified service technician. These regular visits may include (among other things) checks for:

- Motor operation
- Ductwork air leaks
- Coil & drainpan cleanliness (indoor & outdoor)
- Electrical component operation & wiring check
- Proper refrigerant level & refrigerant leaks
- Proper airflow
- Drainage of condensate
- Air filter(s) performance
- Blower wheel alignment, balance & cleaning
- Primary & secondary drain line cleanliness
- Proper defrost operation (heat pumps)

There is some routine maintenance procedures you can do to help keep your system operating at peak performance between visits.

### **Air Filter**

Inspect air filters at least monthly and replace or clean as required. Disposable filters should be replaced. Washable filters may be cleaned by soaking in mild detergent and rinsing with cold water. Replace filters with the arrows pointing in the direction of airflow. Dirty filters are the most common cause of poor heating / cooling performance and compressor failures.

### **Indoor Coil**

If the system has been operated with a clean filter in place, it should require minimal cleaning. Use a vacuum cleaner and soft brush attachment to remove any accumulation of dust from the top and underside of the finned coil surface. However, perform this maintenance only when the coil is completely dry.

If the coil cannot be cleaned by this method, call your dealer for service. It may need a detergent solution and rinsing with water for cleaning, which may require coil removal. You should not attempt this yourself.

### **Condensate Drain**

During cooling season check at least monthly for free flow of drainage and clean if necessary.

### **Condenser Coils**

Grass cuttings, leaves, dirt, dust, lint from clothes dryers, and fall off from trees can be drawn into coils by movement of the air. Clogged condenser coils will lower the efficiency of your unit and could cause damage to the condenser. Periodically, debris should be brushed from the condenser coils.

## **⚠ WARNING**

### ***SHARP OBJECT HAZARD!***

Condenser coils have sharp edges. Wear adequate body protection on body extremities (e.g. gloves). FAILURE TO FOLLOW THIS WARNING COULD RESULT IN BODILY INJURY.

Use a soft bristle brush with light pressure only. DO NOT damage or bend condenser coil fins. Damaged or bent fins may affect unit operation.

### **Painted Surfaces**

For maximum protection of the unit's finish, a good grade of automobile wax should be applied every year. In geographical areas where water has a high concentration of minerals (calcium, iron, sulfur, etc.). It is recommended that lawn sprinklers not be allowed to spray the unit. In such applications, the sprinklers should be directed away from the unit. Failure to follow this precaution may result in premature deterioration of the unit finish and metal components.

In sea coast areas, special maintenance is required due to the corrosive atmosphere provided by the high salt concentration in ocean mists and the air. Periodic washing of all exposed surfaces and coil will add additional life to your unit. Please consult your installing dealer for proper procedures in your geographic area.

---

## **IF YOUR SYSTEM DOES NOT WORK, BEFORE REQUESTING A SERVICE CALL:**

---

1. Ensure thermostat is set below (cooling) or above (heating) room temperature and that the system lever is in the "COOL", "HEAT" or "AUTO" position.
2. Inspect your return air filter: If it is dirty your air conditioner may not function properly.
3. Check indoor and outdoor disconnect switches. Confirm circuit breakers are ON or that fuses have not blown. Reset breakers/replace fuses as necessary.
4. Inspect the outdoor unit for clogged condenser coils, (grass cuttings, leaves, dirt, dust or lint). Ensure that branches, twigs or other debris are not obstructing the condenser fan.

## **IF YOUR SYSTEM STILL DOES NOT OPERATE, CONTACT YOU SERVICING DEALER.**

Be sure to describe the problem, and have the model and serial numbers of the equipment available.

# OUTDOOR EQUIPMENT LIMITED WARRANTY

(Not applicable outside the U.S.A. and Canada.)

**GENERAL FIVE YEAR PART WARRANTY** - (hereinafter referred to as the *company*) warrants the product to be free from defects in material and workmanship under normal use and maintenance for a period of five (5) years in residential applications (one (1) year for commercial) on all components, except compressors as noted below. The warranty period begins on the date of original installation whether or not actual use begins on that date. If the date of original installation cannot be verified, the warranty begins on the date of manufacture plus six (6) months. At the *Company's* sole option, a new or re-manufactured part to replace any defective part will be provided without charge for the part itself; PROVIDED the defective part is returned to our distributor through a qualified servicing dealer or contractor. The replacement part assumes the unused portion of the factory warranty. Residential application is defined as a single family or multi-family dwelling.

**COVERED PARTS INCLUDE** - accumulator, capacitor, condenser coil, contactor, expansions device, fan blade, fan motor, muffler, reversing valve, service valve, solenoid valve, unit mounted sensors and switches, if present.

**2HP13 FIVE YEAR COMPRESSOR WARRANTY** - The compressor in the above listed product is warranted to be free from defects in material and workmanship under normal use and maintenance for a period of five (5) years. The compressor will be provided without charge for the compressor itself; PROVIDED the defective compressor is returned to our distributor through a qualified servicing dealer or contractor. The replacement compressor assumes the unused portion of the factory warranty.

**THIS WARRANTY DOES NOT INCLUDE LABOR OR OTHER COSTS** - incurred for diagnosing, repairing, removing, installing, shipping, servicing, or handling of either defective parts or replacement parts or complete unit. Other costs not covered include items such as any materials not listed above, refrigerant and refrigerant reclaiming. Such costs may be covered by a separate warranty provided by the installing dealer or contractor.

#### **THESE WARRANTIES APPLY ONLY:**

- *To products in their original installation location and become void upon re-installation.*
- *To units installed with indoor coil combinations listed in the Air-Conditioning and Refrigeration Institute (ARI) Directory of Certified Unitary Equipment.*

**EXCEPTIONS TO LIMITED WARRANTY** - When the outdoor unit is installed in non-residential applications; in these cases the compressor is warranted for 5 years.

**LIMITATIONS OF WARRANTIES** - All implied warranties (including implied warranties of merchantability) are hereby limited in duration to the period for which the limited warranty is given. Some states do not allow limitations on how long an implied warranty lasts, so the above may not apply to you. The expressed warranties made in this warranty are exclusive and may not be altered, enlarged, or changed by any distributor, dealer, contractor or other person whatsoever.

#### **THE COMPANY WILL NOT BE RESPONSIBLE FOR:**

1. Failure to start due to voltage conditions, blown fuses, open circuit breakers or other damages due to the inadequacy or interruption of electrical service;
2. Damage as a result of floods, winds, fires, lightning, accidents, corrosive environments or other conditions beyond the control of the *Company*;
3. Damage or repairs required as a consequence of faulty installation, misapplication, abuse, improper servicing, unauthorized alteration or improper operation;
4. Normal maintenance as outlined in the installation and servicing instructions or owner's manual including coil cleaning, filter cleaning and/or replacement and lubrication;
5. Parts not supplied or designated by the *Company*, or damages resulting from their use;
6. The *Company* products installed outside the United States of America and Canada;
7. Electricity or fuel costs or increases in electricity or fuel costs for any reason whatsoever including additional or unusual use of supplemental electric heat;
8. **ANY SPECIAL INDIRECT OR CONSEQUENTIAL PROPERTY OR COMMERCIAL DAMAGE OF ANY NATURE WHATSOEVER.** Some states do not allow the exclusion of incidental or consequential damages, so the above limitation may not apply to you.

***This warranty gives you specific rights, and you may also have other rights that vary from state to state.***

**Keep this book and your sales slip together for future reference. You must provide proof of purchase or installation date for in-warranty service.**

Write down the following information about your unit to better help you obtain assistance or service if you ever need it. You will need to know the complete model and serial number. You can find this information on the unit rating plate.

**Dealer Name:** \_\_\_\_\_

**Address:** \_\_\_\_\_

**Phone Number:** \_\_\_\_\_

**Indoor Model Number:** \_\_\_\_\_ **Serial Number:** \_\_\_\_\_

**Indoor Model Number:** \_\_\_\_\_ **Serial Number:** \_\_\_\_\_

**Installation Date:** \_\_\_\_\_